

DWD 102

Digi-Wave™ Dual-Bay Docking Station



tourguide
SYSTEMS
from applesound Ltd

NEW! The Digi-Wave Dock offers an innovative extension to the Digi-Wave two-way wireless communication system from Williams Sound. It provides a simple, flexible way to connect portable Digi-Wave systems to other fixed systems. The connection begins when a Digi-Wave transceiver or receiver is simply plugged into the Dock. The Dock provides continuous power and/or charging for two Digi-Wave devices, and has separate audio inputs and outputs in each of its bays.

Digi-Wave™ Dual-Bay Docking Station

DWD 102 Rear Panel

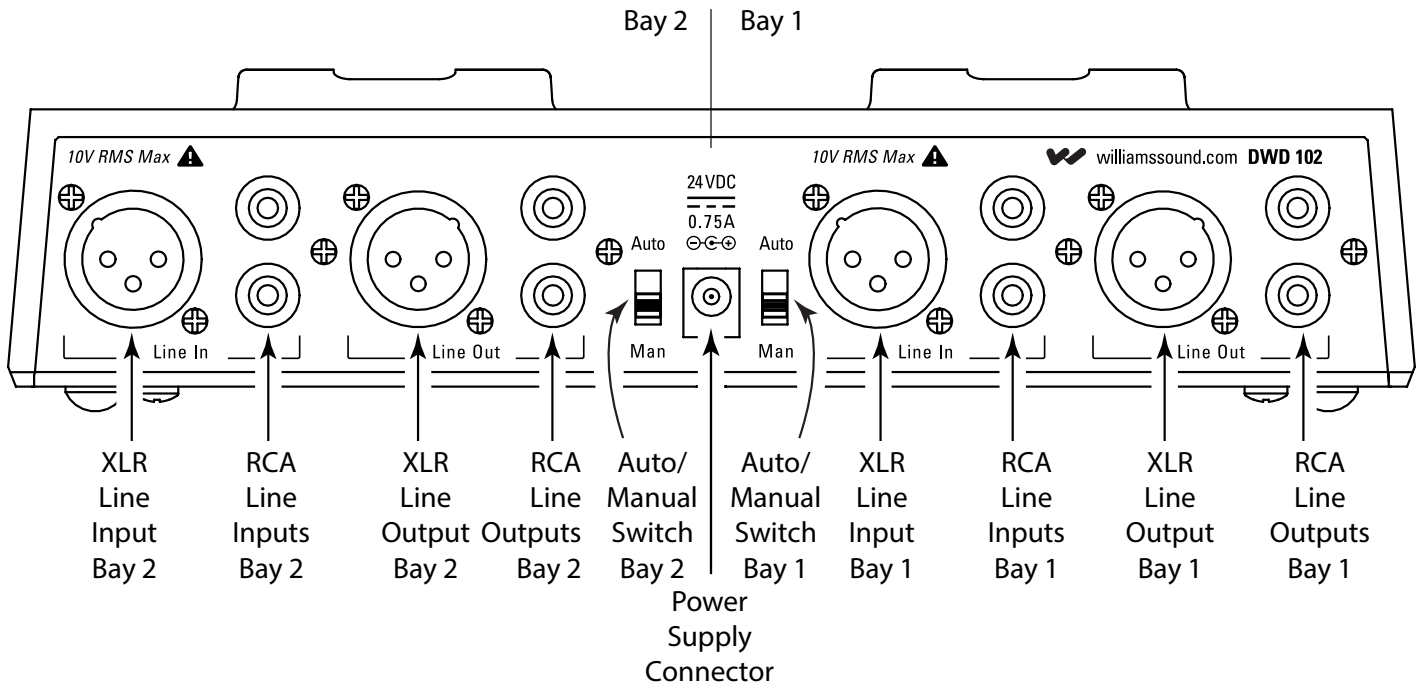

DWD 102 Top

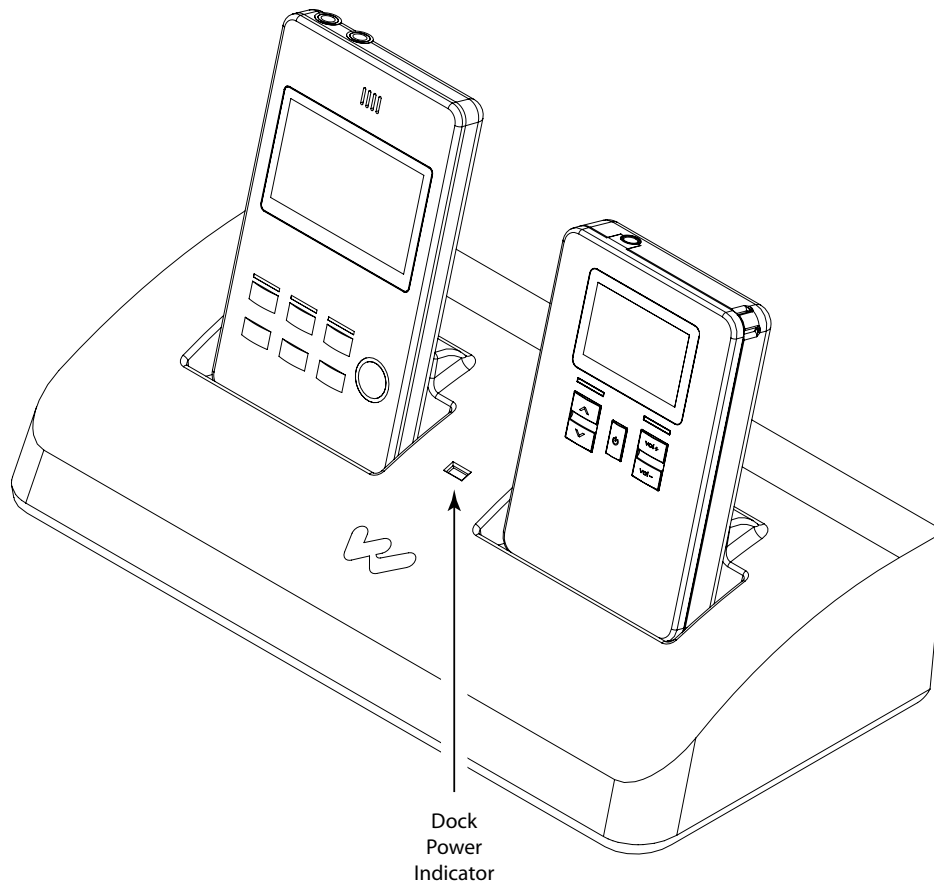

DWD 102 Specifications

Dimensions:	8.88" x 4.34" x 2.16" (226 mm x 110 mm x 55 mm) L x W x H
Shipping Weight:	1.4 lbs (0.64 kg)
Enclosure:	Black, heavy duty plastic molded top, with metal base and non-skid rubber feet. White legends on back.
DC Power Input:	2.5mm ID barrel connector, 24VDC input, 750mA, Center Positive.
Power Supply:	Williams Sound TFP 048. Input: 100-240VAC 50/60Hz, 18W. Output: 24VDC, 750mA.
Charging Time:	DLT 100 2.0: 5 hours nominal (internal Lithium Polymer Battery) DLR 60 2.0: 5 hours nominal, based on Williams Sound NiMH battery BAT 022-2.
Unit Capacity:	2 Units: DLT 100 2.0, DLR 60 2.0, or DLR 60. DLT 100 units will charge only (no audio).
Indicators:	Green LED indicating power at the charger/dock. Charging status is shown on unit being charged.
Rear Inputs:	One set of L/R RCAs and one female XLR per bay.
Rear Outputs:	One set of L/R RCAs and one male XLR per bay.
Dock Connector:	One 30-pin connector per bay. Supports power/charging, audio in, audio out, and control signals.
Controls:	One 2-position switch per bay, for "manual" or "auto" mode.
Warranty:	2 Years
Approvals:	FCC, CE, C-v, Industry Canada, RoHS2, CB scheme, Energy Star V

NOTE: SPECIFICATIONS SUBJECT TO CHANGE WITHOUT NOTICE!

Architectural / Engineering Specifications

DWD 102

The docking station shall be a two bay docking station for use with Digi-Wave DLT100 and DLR 60 products. It shall be powered by a 24VDC power supply and can recharge the batteries in the Digi-Wave products while they are docked. It shall be housed in a black heavy-duty plastic with a steel base and measure 8.9" x 4.34" x 2.16". The docking station shall have a green power on LED on its top panel.

It shall have the ability to connect to an audio system allowing Digi-Wave transceivers and receivers to supply or take audio to that audio system. Each bay shall have balanced XLR input and output as well as unbalanced RCA input and output. Each bay shall have a two position switch to select auto (automatically turns on the Talk button and power to the DLT 100) or manual which leaves the talk and power selecting to the user.

The docking station shall be CE, C-v, Industry Canada and RoHS2 compliant and covered by a two year parts and labor warranty.

This docking station shall be the Williams Sound model DWD 102.

www.tourguide-systems.co.uk/sennheiser

Search: @TourguideSYS

Tel. +44 (0)1244 456 899



WILLIAMS AV
info@williamsav.com / www.williamsav.com
800-843-3544 / INTL: +1-952-943-2252