



www.tourguide-systems.co.uk

Search: @TourguideSYS

Tel. +44 (0)1244 456 899

UNITE

DIGITAL WIRELESS COMMUNICATION SYSTEM

OPERATING INSTRUCTIONS

beyerdynamic

1. Safety instructions	4
1.1 Chargers	4
1.2 Transmitters / receivers	5
2. Disposal	6
3. Simplified EU declaration of conformity	6
4. Approvals	6
5. Simple initial operation of the Unite system with one transmitter and factory-set group ID	7
6. System information	8
6.1 DECT	8
6.2 Operating range	8
6.3 Automatic frequency and group management	8
6.4 Encryption	11
7. Create/define a new pairing	12
8. Charging	13
8.1 Unite CC-24P Cockpit charger	14
8.1.1 Operating elements	14
8.1.2 How to operate the Cockpit charger	15
8.1.3 Mains connection	15
8.1.4 Automatic Firmware Update	15
8.1.5 Conditioning the battery	15
8.1.6 Service mode	15
9. Devices	16
9.1 Unite TP bodypack transmitter	16
9.1.1 Supplied accessories	16
9.1.2 Operating elements	16
9.1.3 How to wear the bodypack transmitter	17
9.1.4 How to connect a headphone/headset/induction loop	17
9.1.5 How to connect a microphone	17
9.1.6 How to connect an external audio source	18
9.1.7 Switching on or off	18
9.1.8 Set the channel name	19
9.1.9 Adjust the volume	19
9.1.10 Mute function	19
9.2 Unite RP / RP-T bodypack receiver	20
9.2.1 Supplied accessories	20
9.2.2 Operating controls	20
9.2.3 How to wear the bodypack receiver	21
9.2.4 How to connect a headphone/headset/induction loop	21
9.2.5 Switching on or off	22
9.2.6 Adjust the volume	23
9.2.7 Speaking to the guide (RP-T only)	23
10. Menu items	24
10.1 General	24
10.2 "Audio" main menu	25
10.2.1 Basic audio settings	25
10.2.2 Set input effects	26
10.3 "Talkback" main menu	27
10.4 "Bluetooth" main menu	27
10.5 "System" main menu	28
11. Special features	29
11.1 Device mode / Sub-Master configuration	29
11.2 Talkback function (RP-T)	29
11.3 NOM - Number of open microphones	30
11.4 Channel search	31
11.5 External interfaces (analogue line-in; USB interface; Bluetooth®)	31
12. Special functions	32
12.1 Button lock	32
12.2 Automatic headset recognition	32
12.3 Automatic power off	32
13. Accessories	33

14. Overview Unite components 33

15. Technical specifications 34

You have selected the digital wireless Unite communication system from beyerdynamic. Thank you for your trust. Please take a few minutes to read these operating instructions carefully before use.

The Unite system is versatile for various applications and offers optimum digital sound transmission, for example for group tours in companies or museums or for multilingual meetings in conjunction with a wireless interpretation system.

The Unite systems consists of the following components:

- Unite RP bodypack receiver
- Unite TP bodypack transmitter
- Unite TH handheld transmitter
- Unite CC-24P charging case
- Unite CR-12P charger for rack mounting
- Unite CU-8P, Unite CU-4P desktop chargers
- Unite AP-4 access point

1. Safety instructions

General

- Please READ this user manual before the first use.
- Please KEEP this user manual.
- Please FOLLOW the specified operating and safety instructions.

Disclaimer

- beyerdynamic GmbH & Co. KG will not be liable for any damage to the product or injury to persons caused by negligent, improper, incorrect or inappropriate operation of the product.

1.1 Chargers



The lightning flash within an equilateral triangle is intended to alert the user to the presence of uninsulated dangerous voltage within the device that may be sufficient enough to constitute a risk of electric shock to users.



The exclamation mark within an equilateral triangle is intended to alert the user to the presence of important operating and maintenance instructions in the literature accompanying the product.

1. Read these instructions.
2. Keep these instructions.
3. Heed all warnings.
4. Follow all instructions.
5. Do not use this apparatus near water.
6. Clean only with dry cloth.
7. Do not block any ventilation openings. Install in accordance with the manufacturer's instructions.
8. Do not install near any heat sources such as radiators, heat registers, stoves, or other apparatus (including amplifiers) that produce heat.
9. Do not defeat the safety purpose of the polarized or grounding-type plug. A polarized plug has two blades with one wider than the other. A grounding type plug has two blades and a third grounding prong. The wide blade or the third prong are provided for your safety. If the provided plug does not fit into your outlet, consult an electrician for replacement of the obsolete outlet.
10. Protect the power cord from being walked on or

pinched particularly at plugs, convenience receptacles, and the point where they exit from the apparatus.

11. Only use attachments/accessories specified by the manufacturer.
12. Use only with the cart, stand, tripod, bracket, or table specified by the manufacturer, or sold with the apparatus. When a cart is used, use caution when moving the cart/apparatus combination to avoid injury from tip-over.
13. Unplug this apparatus during lightning storms or when unused for long periods of time.
14. Refer all servicing to qualified service personnel. Servicing is required when the apparatus has been damaged in any way, such as power supply cord or plug is damaged, liquid has been spilled or objects have fallen into the apparatus, the apparatus has been exposed to rain or moisture, does not operate normally, or has been dropped.

Location

- The equipment must be set up so that the mains switch, mains plug and all connections on the rear of the device are easily accessible.
- If you transport the equipment to another location take care to ensure that it is adequately secured and can never be damaged by being dropped or by impacts on the equipment.

Fire hazard

- Never place naked flames (e.g. candles) near the equipment.

Humidity / heat sources

- Never expose the equipment to rain or a high level of humidity. For this reason do not install it in the immediate vicinity of swimming pools, showers, damp basement rooms or other areas with unusually high atmospheric humidity.
- Never place objects containing liquid (e.g. vases or drinking glasses) on the equipment. Liquids in the equipment could cause a short circuit.
- Do not install near any heat sources such as radiators, heat registers, stoves or other device (including amplifiers) that produce heat.

Connection

- The equipment must be connected to a mains socket that has an earth contact.
- Protect the power cord by not walking or standing on it or pinching, this is considered for plugs especially where they exit from the device.
- Lay all connection cables so that they do not present a trip hazard.
- Whenever working on the equipment switch off all inputs and outputs to the power supply.
- Check whether the connection figures comply with the existing mains supply. Serious damage could occur due to connecting the system to the wrong power supply. An incorrect mains voltage could damage the equipment or cause an electric shock.
- Please note that different operating voltages require the use of different types of power cable and plugs. Please refer to the following table:

Voltage	Power plug according to standard
110 - 125 V	UL817 and CSA C 22.2 no. 42.
220 - 230 V	CEE 7 page VII, SR section 107-2-D1/IEC 83 page C4.
240 V	BS 1363 (1984): "Specification for 13A fused plugs and switched and un-switched socket outlets."

disconnect it from the mains and have it checked and repaired.

- Do not hold the mains cable with wet hands. There must be no water or dust on the contact pins. In both cases you could receive an electric shock.
- The mains cable must be firmly connected. If it is loose there is a fire hazard.
- Always pull out the mains cable from the mains and/or from the equipment by the plug – never by the cable. The cable could be damaged and cause an electric shock or fire.
- Do not use the equipment if the mains plug is damaged.
- If you connect defective or unsuitable accessories, the equipment could be damaged. Only use connection cables available from or recommended by beyerdynamic.

Switching off

- When switching off the device, also disconnect the power plug from the power socket. Make sure that you do not pull on the cable, but on the power plug.

Ventilation

- Do not insert objects into the ventilation grilles or other openings. You could damage the equipment and/or injure yourself.

Disconnect

- For pluggable equipment, the socket-outlet shall be near the equipment and shall be easily accessible.

Maintenance

- Only clean the equipment with a slightly damp or dry cloth. Never use solvents as these damage the surface.

Trouble shooting and servicing

- Never open the device yourself.
- Leave all service work to authorised expert personnel.

Charging

- A completely new battery may need to be charged and discharged several times before it has reached its full charge capacity.
- Do not throw used batteries in the household waste, but hand them over to the local collection points.
- High ambient temperatures during charging (> +40 °C) affect the efficiency of the charging process and the life-time of the rechargeable battery.

1.2 Transmitters / receivers

General

- Protect the transmitter/receiver from moisture and sudden impacts. You could either injure yourself or others or damage the transmitter/receiver.

Trouble shooting and servicing

- Never open the device yourself.
- Leave all service work to authorised expert personnel.

Maintenance

- Only clean the equipment with a slightly damp or dry cloth. Never use solvents as these damage the surface..

Rechargeable battery

- The transmitter/receiver is operated with the following battery type: BAT-3707, lithium-ion, 3.7 V, 1.88 Ah, 6.96 Wh (order no. 727.679)
- Use only a USB 2.0/3.0 compliant 5V power supply to charge the battery pack via the integrated USB type-C port (power consumption is max. 500 mA).
- High temperatures, particularly in association with a high charging status, result in irreversible damage of the battery pack.
- If you are not intending to use the battery for an extended period or are planning to put it into storage, it is advisable to lower the battery's charging level to around 50% and to store it at temperatures of maximum 30 °C.
- In order to ensure safe transport by land, sea and air, the battery pack used for the bodypack transmitter is tested according to the UN 38.3 transport regulation for lithium-ion batteries.
- Misuse or improper use could damage the battery pack. In extreme cases, there is a risk of explosion, heat, fire, smoke or gas.
- Never expose the battery pack to excessive heat such as sunshine, fire or the like.
- Do not expose the battery pack to mechanical shock.
- Charge the battery pack before initial use.
- Use the specified chargers for charging the battery pack.
- Avoid complete draining of the battery. This could damage the battery and shorten its service life.
- If you do not use the transmitter for several months, the batteries should be charged at least twice a year to prevent deterioration in performance due to self-discharge.
- Clean the charging contacts of the transmitter with a clean dry cloth, if they become dirty.
- Do not short-circuit the battery.
- The charging contacts could cause property damage, injuries or fire damage if they come into contact with conductive materials such as jewellery, keys or chains. This can lead to a closed electric circuit and, therefore, to the material overheating. To avoid this kind of unintentional electric circuit, the charging contacts must be handled with care. This is especially important if the transmitter is transported in a bag or another container containing other metallic objects.

Moisture / heat sources

- Keep the battery pack clean and dry. Never expose the device to rain or high humidity. Do not install it in the immediate vicinity of swimming pools, shower facilities, damp basements or other areas with unusually high air humidity.
- Never place objects filled with water (e.g. vases or drinking glasses) on the device. Liquids in the devices may cause a short circuit.
- Never install or operate the device in the immediate vicinity of radiators, lighting systems or other heat-generating devices.

Unite TH handheld transmitter

- Do not blow into the microphone. In a condenser microphone this could damage the transformer. It is preferable to carry out a speech trial.

Unite TP bodypack transmitter

- Clip-on microphones are often very compact. If they are accidentally swallowed there is a risk of choking. Always keep this type of microphone away from small children.

5. Simple initial operation of the Unite system with one transmitter and factory-set group ID

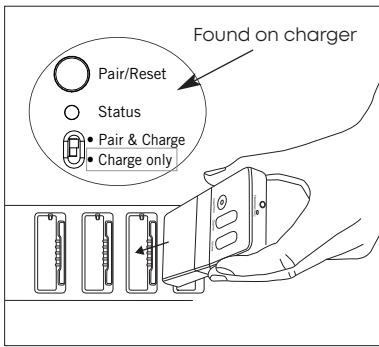

1. Before initial operation, charge the battery in the Unite receiver and Unite transmitter with a Unite charger. Set the switch on the Unite charger to the "Charge only" position.

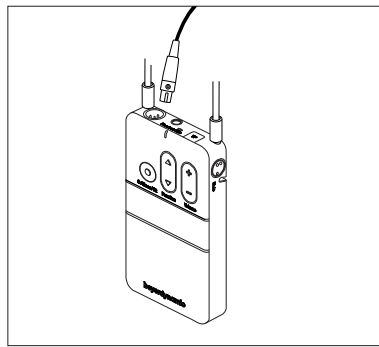

2. Connect a microphone or headset to the bodypack transmitter.

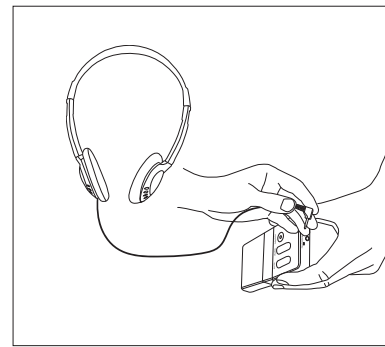

3. Connect headphones to the bodypack receiver.

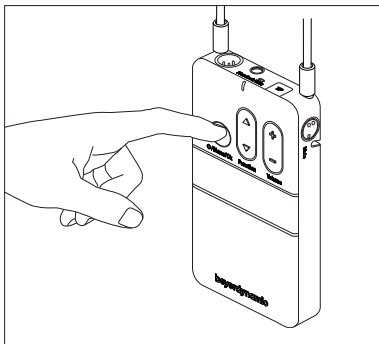

4. Switch on the bodypack transmitter or handheld transmitter by briefly pressing the \odot /Menu/Ok button.

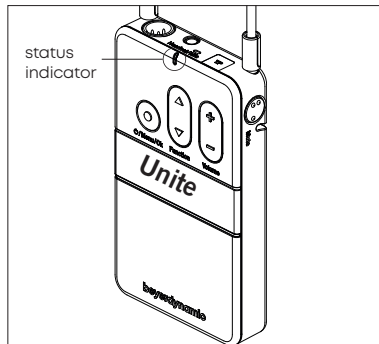

5. The status indicator on the transmitter initially lights red. Once the transmitter has found a suitable frequency, the status indicator lights green to indicate that the transmitter is ready for operation. The factory-set name "Unite" is displayed.

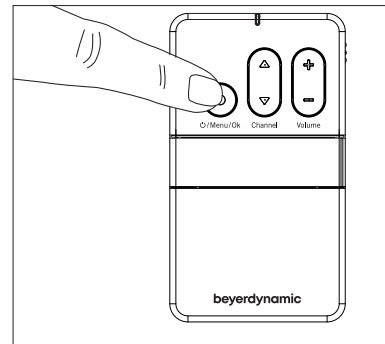

6. Switch on the receiver(s) by briefly pressing the \odot /Menu/Ok button.

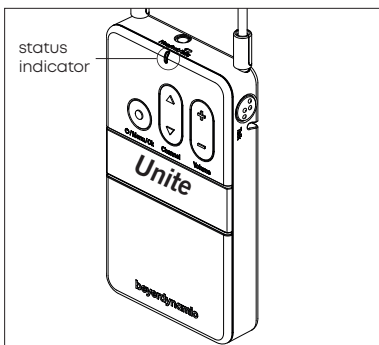

7. The status indicator on the receiver initially lights red. Once the receiver is connected to the transmitter, the status indicator lights green. The "Connecting" message on the receiver display indicates that the connection has been established. As soon as the receiver is connected to the transmitter, the name "Unite", factory-set in the transmitter, is displayed on the receiver. The Unite system is ready for operation.

You will find a detailed description of the Unite system and its operation in the following chapters of the system manual.

6. System information

6.1 DECT

Unite is based upon DECT (Digital Enhanced Cordless Telecommunications) technology, an international standard for telecommunications using wireless technology, and known in particular for its use with cordless telephones. Wireless technology enables a device to communicate with a central processing unit.

The modern, future-proof transmission platform in DECT standard means the system can be used worldwide without registration and free of charge. In addition, DECT systems offer outstanding security as for each connection the receiver is required to register with the transmitter using a confidential code. Below 2.4 GHz, DECT uses different frequencies to WLAN, Bluetooth®, etc. and therefore causes no interference with these networks.

6.2 Operating range

Unite is able to bridge very great distances between the various device types. Peak values up to 300m can be achieved in open areas. There are various influencing factors inside buildings. Operating range is restricted by the number and composition of walls, ceilings and floors. Performance is inevitably restricted as a result of absorption and reflection of the high frequency range. For example, reinforced concrete absorbs frequencies to a certain extent, whereas a metal-clad ceiling reflects them.

A further influencing factor is the number of active DECT wireless connections conditional upon the frequency band available in each region. In Europe, for example, a maximum of 120 channels can be in use, whereas the maximum for the American market is 60 channels. The total number of connected devices can be much higher than these key indicators, however, since they relate only to the number of simultaneously used DECT radio connections actively occupying a channel.

Actual restriction of the system is generally only to be expected when all influencing factors occur at once. For example: In one area of a building there are 70 simultaneously active DECT telephones; in this same part of the building there are 32 Unite groups, the transmitters of which are attempting to reach their groups through several walls simultaneously. The walls are made of reinforced concrete and all ceilings are metal-clad.

6.3 Automatic frequency and group management

A further benefit of this technology is automatic frequency management. This means you need not worry about frequencies, as the system itself controls transmission and adjusts automatically for secure transmission. It recognises the availability and allocation of frequencies and adjusts dynamically and automatically. Interference signals are identified at an early stage, enabling the system to react immediately. Without the knowledge of the user and/or listener, it switches frequency to ensure uninterrupted operation. The system also identifies all active wireless connections and adapts these dynamically so that individual groups do not interfere with each other. This means Unite can be used in parallel by up to 32 groups. A high operating range and long operating time create stable conditions for transmission.

DECT frequency range		Free of charge and no registration required in:
1880 - 1900 MHz	EU Frequency band	Australia, Austria, Belgium, Bulgaria, Croatia, Cyprus, Czech Republic, Denmark, Estonia, Finland, France, Germany, Great Britain, Greece, Hong Kong, Hungary, Ireland, Israel, Italy, Jordan, Latvia, Lithuania, Luxembourg, Malaysia, Malta, Moldova, Netherlands, New Zealand, Norway, Poland, Portugal, Romania, Russia, Singapore, Slovakia, Slovenia, South Africa, Spain, Sweden, Switzerland, United Arab Emirates
1893 – 1906 MHz	Japan	Japan
1920 – 1930 MHz	North America	Canada, USA

Table 1

All devices are supplied with the group ID 256 and fixed audio encryption allowing quick and easy setup. This allows for quick and easy initial use. The group ID identifies devices that can be placed in a virtual group. For example, all devices within a building, a tour group or a conference room. The transmitter will only transmit the audio signal to a channel with a predefined channel name. If there are several transmitters in a group, the channel for the respective transmitter can be selected on the receiver. You will need to establish a new pairing if you require several device groups or secure audio transmission that cannot be intercepted by another group using Unite devices. See chapter on "Create/define a new pairing". The factory preset group ID is 256.

To set a group ID between 1 and 255, follow the steps below:

- Make sure that the Unite TP or Unite TH transmitter is already switched on.
- Press and hold the menu button **2** for two seconds to activate the main menu.
- Use the multifunction button **4** on the Unite TP or Unite TH transmitter to select "System" from the menu.
- Press the menu button **2** on the Unite TP or Unite TH transmitter to open the required submenu.
- Use the multifunction button **4** on the Unite TP or Unite TH transmitter to select "Group ID" from the submenu.
- Select the menu button **2** on the Unite TP or Unite TH transmitter to configure group ID.
- Use the multifunction button **4** on the Unite TP or Unite TH transmitter to select the desired group ID.
- Press the menu button **2** on the Unite TP or Unite TH transmitter to confirm the selected group ID.

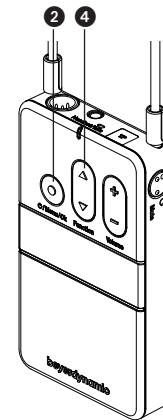

Select a group ID on the transmitter

Important:

Make sure that you select the same group ID for all devices within a desired group. Only devices with the same group ID can communicate with one another. Transmitters with a different group ID are faded out. See diagram: "Set Group ID".

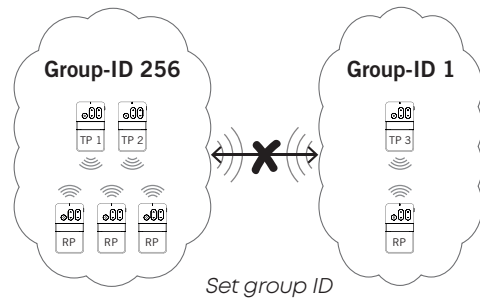

Set group ID

Devices combined under a group ID can use this group ID to transmit several audio channels. In order to differentiate between audio channels from several transmitters on the receiver, enter a five-digit name for the channel on the transmitter. Follow these steps:

- Make sure that the Unite TP or Unite TH transmitter is already switched on.
- Press and hold the menu button **2** for approx. two seconds to activate the main menu.
- Use the multifunction button **4** the select "System" from the menu.
- Briefly press the menu button **2** to open the required submenu.
- Use the multifunction button **4** to select the "Channel Name" submenu.
- Briefly press the menu button **2** to enter the channel name.
- Use the multifunction button **4** to scroll through the characters. When the requested character appears, confirm using the menu button **2**. You can enter five characters at maximum.
- As soon as you select the configured transmitter on the receiver, the set name will be displayed on the receiver's display.
- The diagram "Channel Name" shows an example of two transmitters with different channel names, and a receiver that can find both channel names and switch between both transmitters. Finding and/or switching between channels can take several seconds.

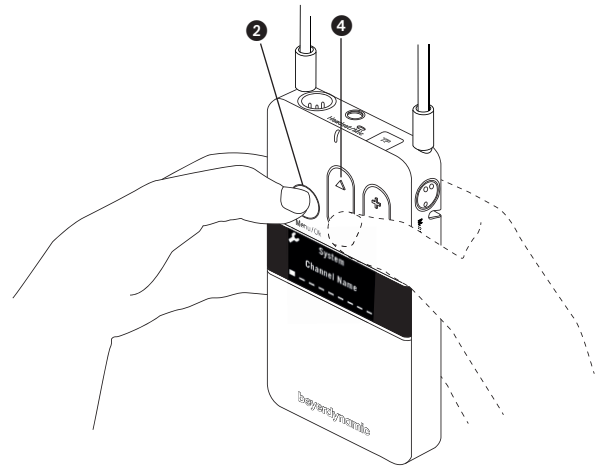

Select "Channel Name" menu item to enter the channel name.

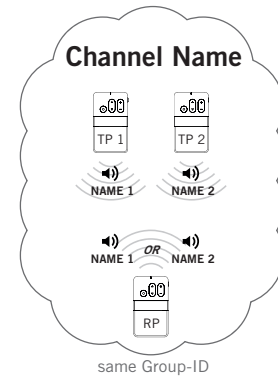

With one receiver you can choose among two transmitters

6.4 Encryption

The audio data is always encrypted with an AES-256 code to ensure a secure transmission against unauthorised listening.

Important: The required key will be generated within the charging unit itself and transmitted to the transmitters and receivers during the pairing process.

As the encryption code is not transmitted wirelessly, the system is better protected against unauthorised listening. Should the receiver receive a differently encrypted audio signal, for which no encryption code has been saved, the received audio signal will be muted. The receiver display will also alternate between showing the relevant channel name and the "KEY!" error message. Encryption of the audio signal is explained schematically in the "Encryption" diagram.

Note: For group ID 256 only, a factory preset code is used that cannot be changed. You can use this group ID for a system without pairing.

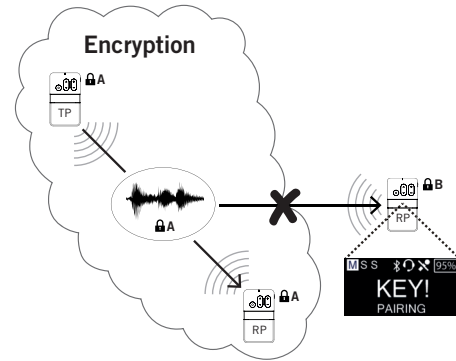

Only transmitter and receiver with the same key can communicate with one another



Important:

The transmitter and receiver can only communicate if the settings for group ID, channel name and encryption match. Transmitters cannot communicate with receivers that do not have the same pairing information. This is shown in the "Encryption" diagram.

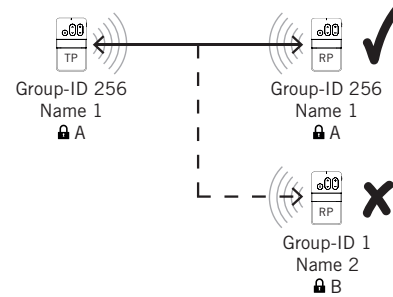

Transmitter and receiver must have the same name and key to communicate with one another

7. Create/define a new pairing

Transmitter and receiver must be paired to enable them to communicate with one another. The code required for this is generated in the charger and transmitted during the pairing process to both transmitter and receiver.



Note: For group ID 256 only, a factory preset code is used that cannot be changed. You can use this group ID for a system without pairing.

To establish a pairing with a charging unit, please proceed as described below:

1. On the transmitter, set the group ID you wish to use for pairing.
2. Insert **one transmitter only** in the charger. If more than one transmitter is used in the charger, pairing will not start and the charger's status indicator ② will show an error message (see table 2). Alternatively you can connect the transmitter using a USB cable connected to the charger's USB port.
3. Insert one or more receivers to be paired with the transmitter into the charger's charging compartment. You can also connect another receiver to the charger using the USB port. Remove all receivers that are **not** to be paired. Should no receiver be connected to the charger, pairing information is stored in the charger only. This is used for later pairing without connecting the transmitter to the charger.
4. To transmit information from the transmitter to the receivers in the charging compartments and to the charger itself for future pairings, hold down the "Pair/Reset" button ① on the charger for more than 2 seconds. The "Status" light ② will flash yellow for a few seconds if the pairing is successful. The status light will then remain yellow because the pairing information is now also saved in the charger.
5. If you wish to pair other receivers, remove the transmitter and all receivers from the charger, switch to "Pair & Charge" ③ and insert the unpaired receivers into the charger. The pairing information will be saved immediately in the unpaired receivers. The status light on the receiver will rapidly flash yellow while this happens.
6. If you have no further devices to pair, switch the charger to "Charge only" ③.
7. Switch on the transmitter and one receiver to check that they have both been paired successfully. After a few seconds the status light on the receiver will light up green and show the channel name of the transmitter.
8. To delete pairing information stored in the charger, hold the "Copy/Reset" button down for more than 5 seconds. The status light ② will then remain permanently green.

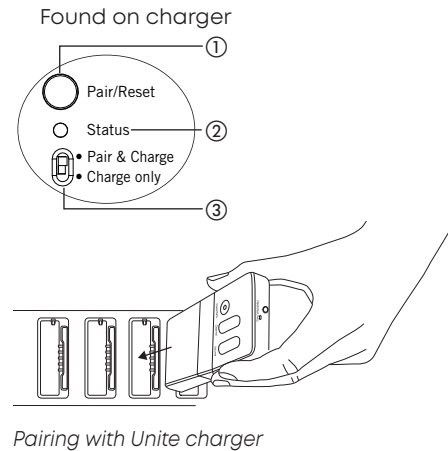

In pairing mode (switch to "Pair & Charge"), the status light ② on the charger will display the following information:

Display	Status
Off	The device is switched off
Green	• Device is ready to use • No pairing information saved
Flashing yellow	Pairing information is being copied to the charger or receiver
Yellow	Pairing information has been stored in the charger
Flashing green/ yellow	Device is being localised
Flashes red 5 times	• No transmitter • Too many transmitters
Flashing red rapidly	• Operating error • Charging error

Table 2

8. Charging



Before using the Unite system for the **first** time, you must charge the batteries integrated in the Unite TP or Unite TH transmitters and Unite RP bodypack receiver. The charging process and relevant charge status is shown on the status light of the transmitter/ receiver.

There are two options for charging the battery:

1. Unite charger

- Connect the charger to an easily accessible power outlet.
- Switch the charger to the position “Charge only” ③ .
- Insert the transmitter/receiver into the charging compartment. Please ensure the device is placed into the charging compartment in such a way as to ensure proper contact with the charger.
- The charging process will start automatically.
- It is not possible to use the transmitter/receiver during charging.

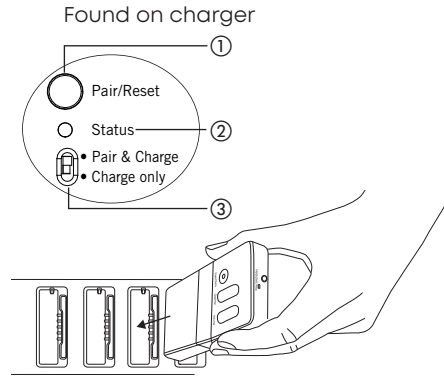

Charging with Unite charger

2. USB power adapter

- Connect a separate USB power adapter to the USB port on the transmitter/ receiver.
- Connect the plug of the USB power adapter to a power outlet.
- The charging process will start automatically.
- It is not possible to use the transmitter/ receiver during charging.

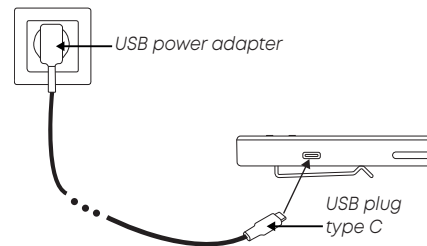

Charging with USB power adapter

- The battery’s charge status is shown on the LED indicator of the relevant transmitter/receiver. See the following table.

Display	Charging status
Off	The device is switched off
Flashing green slowly	Charging mode 0–100%
Green	Battery is charged
Flashing yellow slowly	Pairing information is being copied from the transmitter
10 seconds yellow	Device information successfully copied to charger/devices
Flashing red slowly for 10 seconds	<ul style="list-style-type: none"> • More than one transmitter in the charger at the start of the pairing process • Other pairing errors
Flashing green/yellow rapidly	Device is being localised
Flashing red rapidly	Charging error

Table 3

8.1 Unite CC-24P Cockpit charger

8.1.1 Operating elements

Top view

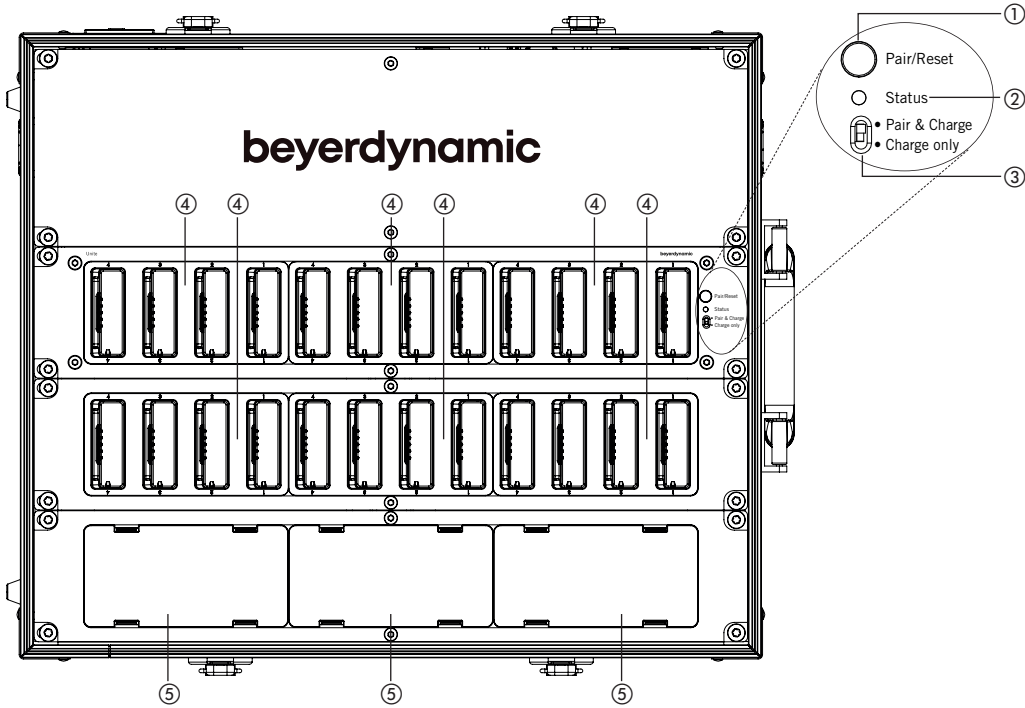

- ① Button for initiating the pairing process or clearing stored pairing information in the charger
- ② Status indicator light for pairing status
- ③ Switch for "Pair & Charge" or "Charge only"
- ④ Charging modules with 4 charging compartments each
- ⑤ Slots for more optional charging modules or one optional charging module and one optional compartment for storing the Unite TH handheld transmitter

Rear view

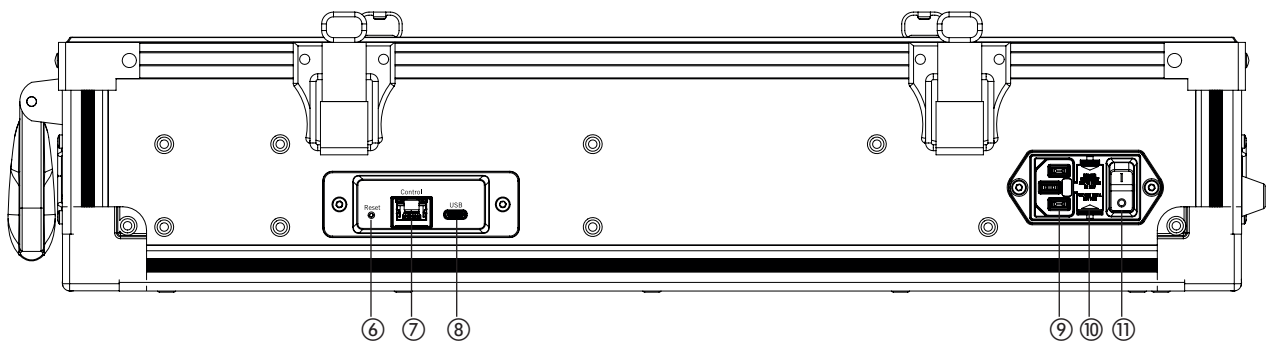

- ⑥ Reset button
- ⑦ Ethernet connection
- ⑧ USB connection
- ⑨ Mains connection
- ⑩ Fuse drawer (2 x 3.15 A fuse, time-lag)
- ⑪ On-off switch

8.1.2 How to operate the Cockpit charger

The Unite CC cockpit case is used for charging the rechargeable batteries inside the bodypack transmitters and receivers as well as transmitting the pairing information from the transmitter to the receivers. The Unite CC-24P has 6 charging units, each with 4 charging compartments so that a maximum of 24 bodypack transmitters or receivers can be charged simultaneously. The Unite CC-36P has 9 charging units each with 4 charging compartments so that a maximum of 36 charging compartments are available.

Warning: When the Cockpit case is in use, do not mount the cover on the case. There is a risk of overheating and fire.

8.1.3 Mains connection

- Connect the IEC connector of the power cable to the mains connection of the charging case. Connect the power plug to a power outlet.
- Switch on the charging case via the on-off switch.
- When not in use, switch off the device and disconnect the power plug from the power socket. Make sure that you do not pull on the cable, but on the power plug.

8.1.4 Automatic Firmware Update

- By using the Unite Cockpit Case you can upload firmware updates to Unite transmitters/receivers.
- With the current factory setting the Unite Cockpit Case will automatically update the firmware of the Unite transmitters/receivers during the **first** charging process. Just insert the transmitters/receivers into the charging compartments.
During the firmware update the status indicator light of the Unite transmitters/receivers will illuminate red. This process will take approx. 5 minutes. Should the process take longer than 10 minutes, turn the Unite Cockpit Case off and on again. The update process will then restart.

Attention:

Please note that after a successful update to a new firmware version, the Unite transmitters/receivers are no longer compatible with older firmware versions.

8.1.5 Conditioning the battery

- In order to achieve the maximum capacity of the battery, we recommend discharging the transmitters/receivers completely to carry out a complete charging cycle afterwards.
- This also increases the accuracy of the battery indicator on the display of the Unite transmitters/receivers.

8.1.6 Service mode

- For maximum operational reliability, the Unite Cockpit Case features a so-called service mode.
- If the device is disconnected from the mains within 45 seconds after being switched on (e.g. by accidental switching off), the device will boot in a safety mode and check itself.
- If this service mode is activated automatically (after booting unsuccessfully), the system will return to its usual operating mode after approx. 3 minutes.

9. Devices

9.1 Unite TP bodypack transmitter

9.1.1 Supplied accessories

- Unite TP bodypack transmitter with mounted belt clip
- Quick start guide
- Neck strap
- Two spare caps for the mute button

9.1.2 Operating elements

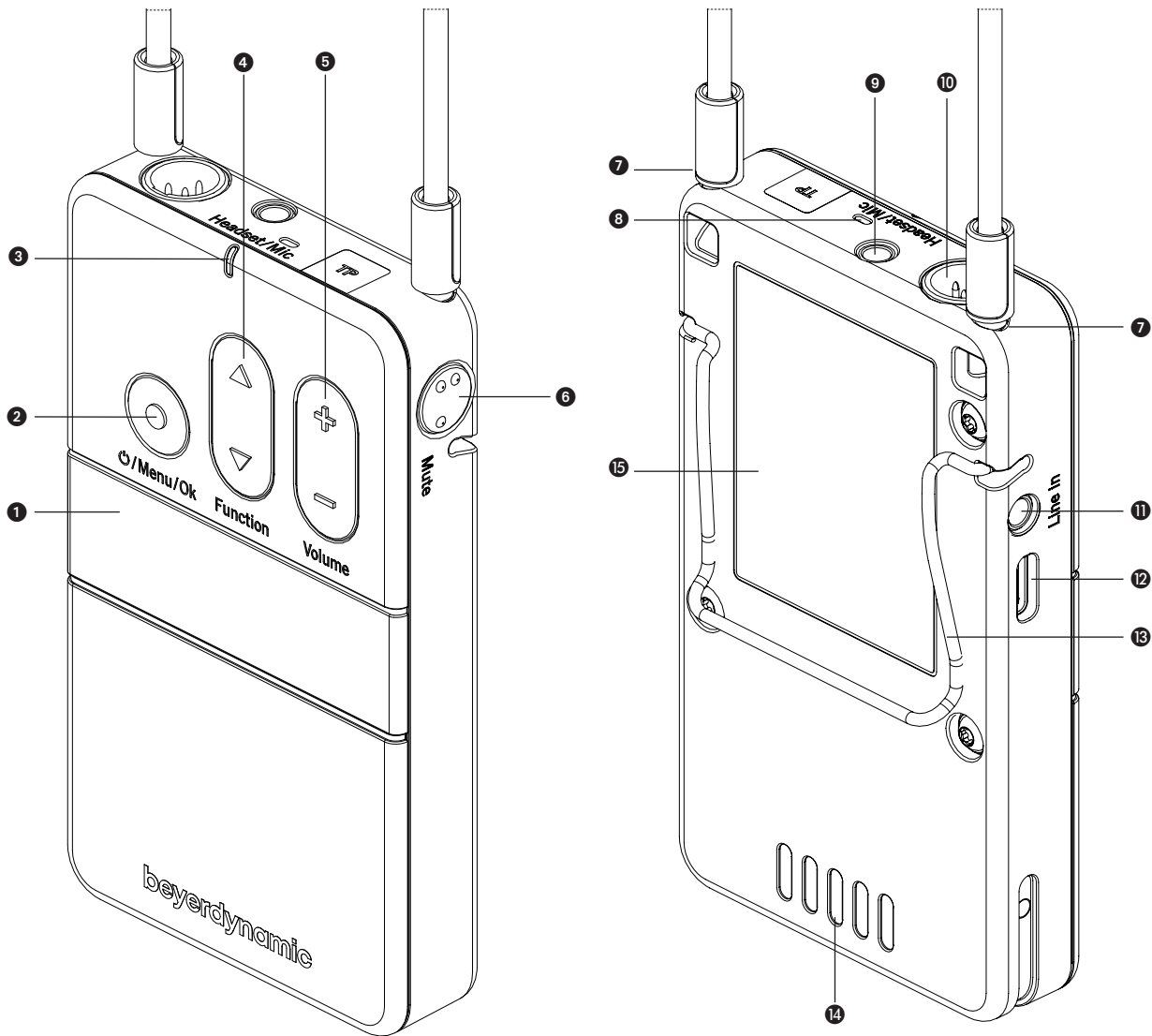

- 1 Display
- 2 On-off and menu button
- 3 Status indicator light
- 4 Multifunction button
- 5 Volume button
- 6 Mute button
- 7 Neck strap attachment
- 8 Integrated microphone

- 9 Headphone/headset/induction loop connection
- 10 Microphone connector
- 11 Line-In, 3-pin jack connector 3.5 mm
- 12 USB port, type C
- 13 Belt clip
- 14 Charging contacts
- 15 Type plate

Please refer to the previous page for the following descriptions.

9.1.3 How to wear the bodypack transmitter

There are two options for wearing the bodypack transmitter:

1. Neck strap

When using the supplied strap, you can wear the bodypack transmitter around the neck. For safety reasons, the fastening will release when pulled strongly.

- Put the pins at the end of the strap into the fastening holes.
- Put the strap around the neck.

2. Belt clip

When using the belt clip, you can attach the bodypack transmitter to clothing such as a trouser or skirt waistband.

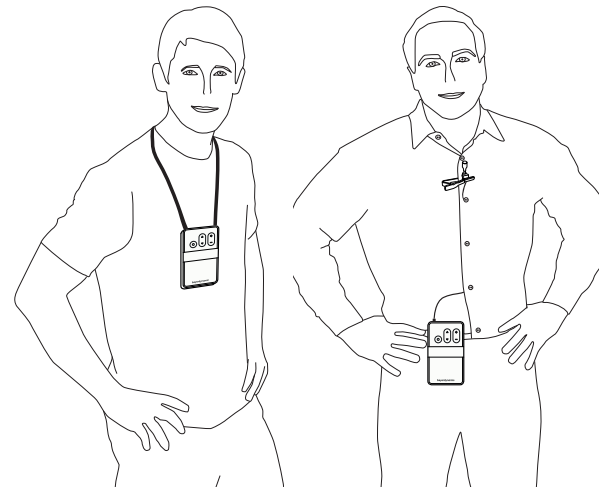

Wear the transmitter around the neck

Wear the transmitter using the belt clip

9.1.4 How to connect a headphone/headset/induction loop

- You can connect headphones, a headset or induction loop to the mini jack socket 9.
- You can control the volume of the connected device with the volume button 5.

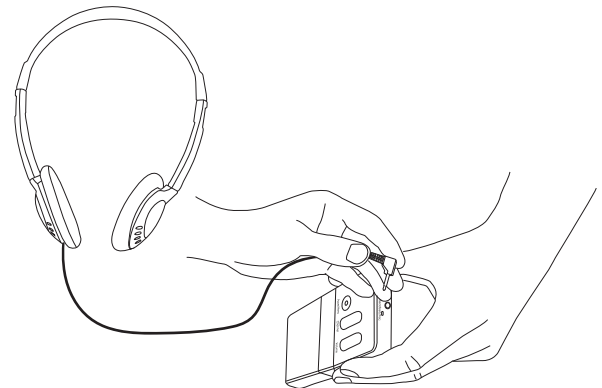

Connect headphones to the bodypack transmitter



Important:

Please note the safety instructions regarding too high volume.

9.1.5 How to connect a microphone

- You can connect a microphone with a 4-pin mini XLR connector to the microphone connector 10. For pin assignment, please refer to the “Technical specifications”.
- The integrated microphone 8 will be activated if the “internal” mode has been selected as an audio source in the menu or if the “auto” mode has been selected when there is no external microphone connected.

Note: The integrated microphone was specially developed for the talkback function in conjunction with the Unite RP-T bodypack receiver for short queries. For best audio transmission we recommend using an external microphone or headset.

- Depending on the microphone, you can adjust the sensitivity of the microphone in the “Audio” main menu under “Volume” in the menu items “Mini XLR Mic”, “Headset Mic” or “Internal Mic”. Refer also to the chapter about the “Menu”.
- With quiet speakers, increase the level. With loud speakers, reduce the level.

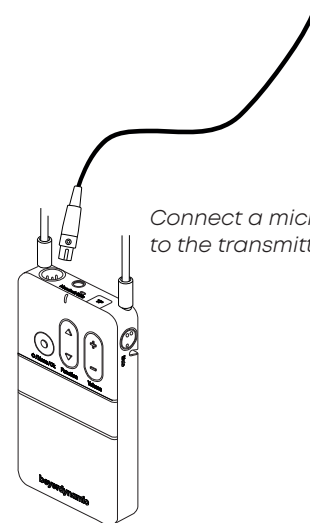

Connect a microphone to the transmitter

*Function probably available from V1.1

9.1.6 How to connect an external audio source

- If required, you can connect an external audio source with a 3-pole mini jack plug (3.5 mm) to the line-in input **10**.
- You can set the sensitivity of the external audio source in the “Audio” main menu under “Volume” via the “Line in” menu item.
- Increase the level for quiet audio sources; reduce level for loud audio sources.

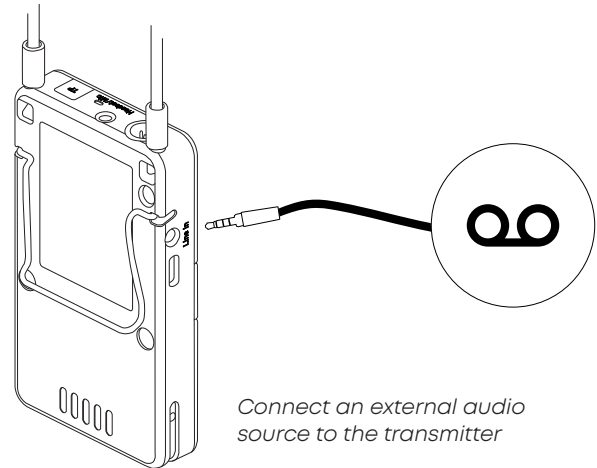

Connect an external audio source to the transmitter

9.1.7 Switching on or off

- To switch on the bodypack transmitter, briefly press the \odot /Menu/Ok button **2**.
- In order to switch off the bodypack transmitter, press the button **2** for approx. 5 seconds.
- When the device is switched on, the status indicator displays the operating status information. See also the following “Status indicator light **3** during operation” table.

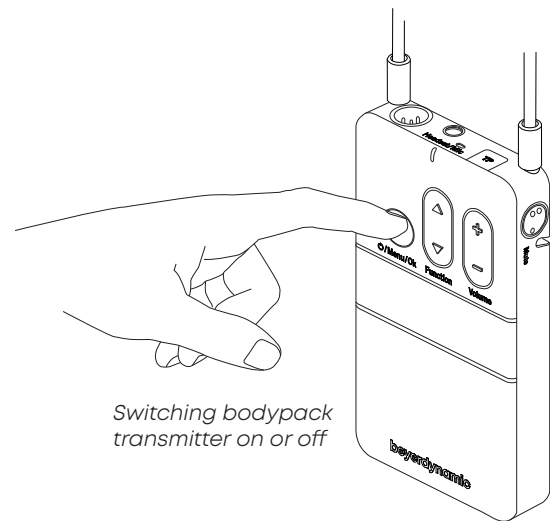

Switching bodypack transmitter on or off

Status indicator light **3** during operation:

Indicator light	Operating status
Off	Device is switched off
Flashing yellow slowly	<ul style="list-style-type: none"> • Ready to operate and battery status > 10% • Out of range (in slave mode only)
Yellow	Connection established and battery status > 10 %
Green	Connection established, audio transmission running (microphone open or another audio source is used) and battery status > 10%
Flashing green slowly	Microphone is muted
Flashing red slowly	Low battery level < 10%
Red	<ul style="list-style-type: none"> • Device is starting • Firmware update is running
Flashing red rapidly	Critical error

Table 4

- When the Unite TP bodypack transmitter is switched on, the adjacent main screen will be displayed indicating that the transmitter is ready for operation.
- The individual symbols mean:
 - 16** Display of all active speakers (Master, 1st slave, 2nd slave)
 - 17** Highlighted display of current type of speaker (Master, 1st slave or 2nd slave)
 - 18** Current channel name
 - 19** Bluetooth® status (various symbols; depending on the status)
 - 20** Headset connected
 - 21** Microphone muted
 - 22** Display of remaining battery capacity
 - 23** Display of the actual speaker

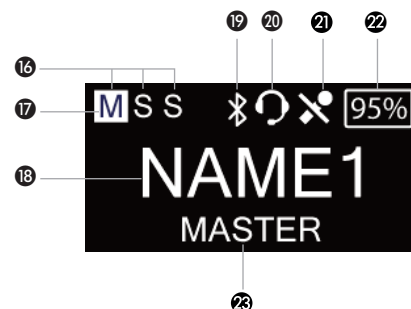

Standard display

9.1.8 Set the channel name

In order to differentiate between audio channels from several transmitters on the receiver, enter a five-digit name for the channel on the transmitter.

Please proceed as described in the following:

- Hold down the menu button **2** on the transmitter for more than 2 seconds to activate the main menu.
- Use the multifunction button **4** to select “System” from the menu.
- Press the menu button **2** to open the required sub-menu.
- Use the multifunction button **4** to select the “Channel Name” sub-menu.
- Press the menu button **2** to set the channel name.
- Use the multifunction button **4** to scroll through the characters. When the desired character appears, confirm using the menu button **2**. You can input max. five characters.
- As soon as you select the configured transmitter on the receiver, the set name will be displayed on the receiver’s display.

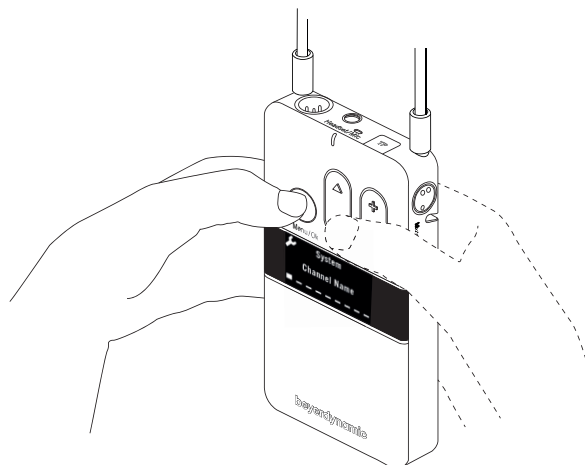

Select “Channel Name” menu item to enter the channel name.

9.1.9 Adjust the volume

Use the volume button **5** to adjust the volume of a connected headphone/headset or induction loop.

- Press “+” to increase the volume.
- Press “-” to reduce the volume.

Important:

 Please note the safety instructions regarding too high volume.

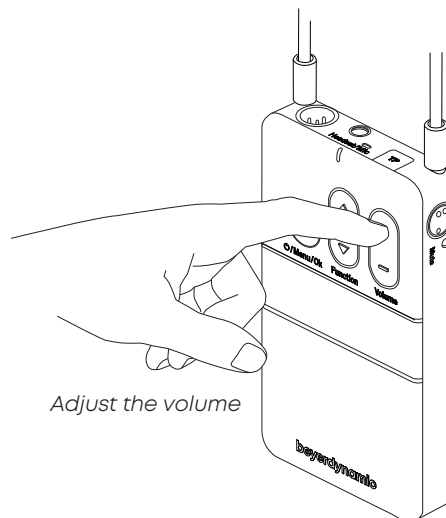

Adjust the volume

9.1.10 Mute function

Use the mute button **6** to mute the internal or externally connected microphone.

- If the “Push” setting is selected in the “Audio / Mute Button” menu, hold the mute button down as long as you want to mute the microphone. See also the separate chapter on “Menu items”.
- If the “Toggle” setting is selected in the “Audio / Mute Button” menu, you will mute the connected or integrated microphone with the first press of the button. With the second press of the button, you will reactivate the microphone. See also the separate chapter on “Menu items”.
- Please keep a distance of approx. 10 cm to the integrated microphone when speaking.

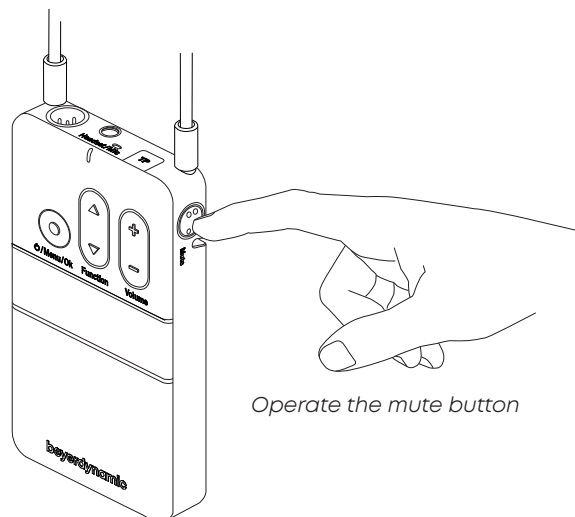

Operate the mute button

9.2 Unite RP / RP-T bodypack receiver

9.2.1 Supplied accessories

- Unite RP or RP-T bodypack receiver with mounted belt clip
- Quick Start Guide
- Neck strap
- Two spare caps for the talkback button

9.2.2 Operating controls

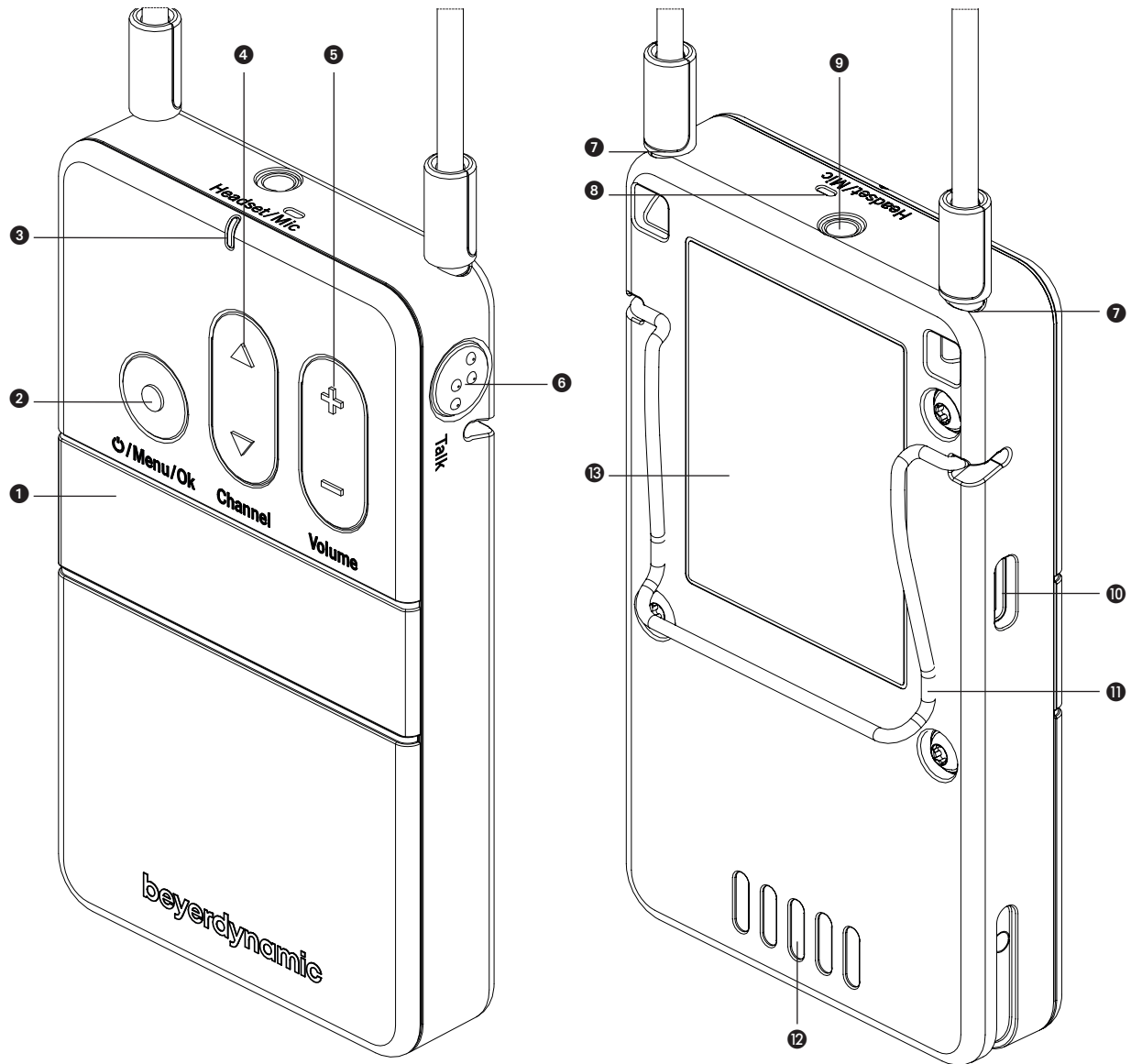

- ❶ Display
- ❷ On-off and menu button
- ❸ Status indicator light
- ❹ Multifunction button
- ❺ Volume button
- ❻ Talkback button (only with RP-T)
- ❼ Neck strap attachment
- ❽ Integrated microphone (only with RP-T)

- ❹ RP: Connection for headphone and induction loop
RP-T: Connection for headphone/headset and induction loop
- ❿ USB port, type C
- ⓫ Belt clip
- ⓬ Charging contacts
- ⓭ Type plate

Please refer to the previous page for the following descriptions.

9.2.3 How to wear the bodypack receiver

There are two options for wearing the bodypack receiver:

1. Neck strap

When using the supplied strap, you can wear the bodypack transmitter around the neck. For safety reasons, the fastening will release when pulled strongly.

- Put the pins at the end of the strap into the fastening holes.
- Put the strap around the neck.

2. Belt clip

When using the belt clip, you can attach the bodypack transmitter to clothing such as a trouser or skirt waistband.

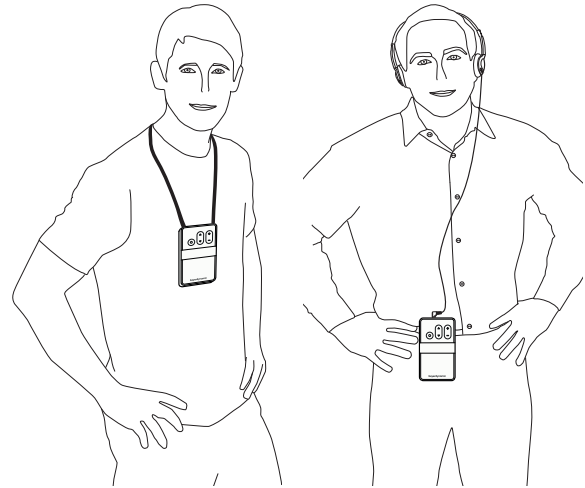

Wear the receiver around the neck

Wear the receiver using the belt clip

9.2.4 How to connect a headphone/headset/induction loop

Unite RP:

- You can connect headphones to the mini jack socket ⑨.
- For those who are hearing impaired, you can connect an induction loop (e.g. IL 200 von beyerdynamic) to the mini jack socket ⑨ instead of headphones.

Unite RP-T:

- Connect headphones or a headset to the mini jack socket ⑨.
- For those who are hearing impaired, you can connect an induction loop (e.g. IL 200 von beyerdynamic) to the mini jack socket ⑨ instead of headphones.

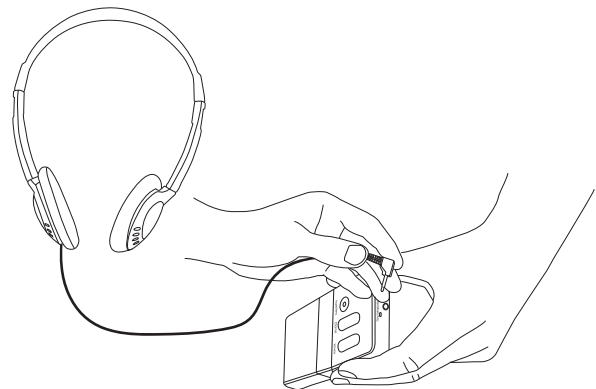

Connect headphones to the bodypack receiver

9.2.5 Switching on or off

- To switch on the bodypack receiver, briefly press the on-off and menu button ②.
- In order to switch off the bodypack receiver, press the button ② for approx. 5 seconds.
- When the device is switched on, the status indicator displays the operating status information. See also the following “Status indicator light ③ during operation” table.

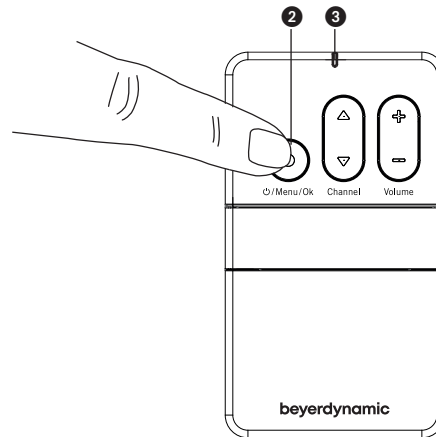

Switching receiver on or off

Status indicator light ③ during operation:

Indicator light	Operating status
Off	Device is switched off
Flashing yellow slowly	<ul style="list-style-type: none"> • Ready to operate and battery status > 10 % • Out of range from transmitter
Yellow	Only for RP-T: Connection established and battery status > 10 %
Green	<ul style="list-style-type: none"> • RP: Connection established and battery status > 10 % • RP-T: Connection established, talkback is running and battery status > 10 %
Flashing red slowly	Low battery level < 10 %
Red	<ul style="list-style-type: none"> • Device is starting • Firmware update is running
Flashing red rapidly	Critical error

Table 5

- When the Unite RP bodypack receiver is switched on, the adjacent main screen will be displayed indicating that the transmitter is ready for operation.
- The individual symbols mean:
 - ⑭ Display of all active speakers (Master, 1st slave, 2nd slave)
 - ⑮ Highlighted display of current type of speaker (Master, 1st slave or 2nd slave)
 - ⑯ Current channel name
 - ⑰ **RP-T only:** Headset connected
 - ⑱ Talkback function activated
 - ⑲ Display of remaining battery capacity

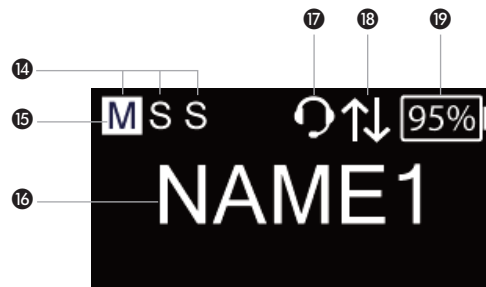

Standard display

9.2.6 Adjust the volume

Use the volume button **5** to adjust the volume of a connected headphone/headset or induction loop.

- Press “+” to increase the volume.
- Press “-” to reduce the volume.



Important:

Please note the safety instructions regarding too high volume.

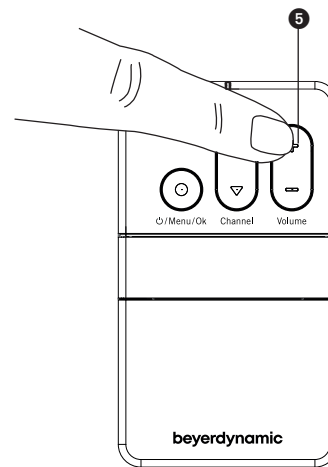

Adjust the volume

9.2.7 Speaking to the guide (RP-T only)

The Unite RP-T bodypack receiver has a talkback button **6** and an integrated microphone **8** for talking to the guide during a tour.

- If the “Push” setting is selected in the “Talkback” menu, press and hold the talkback button as long as you speak into the microphone of a connected headset or the integrated microphone **8** when no headset is connected. Refer to the separate chapter on “Menu items”.
- If the “Toggle” setting is selected in the “Talkback” menu, press the button to activate the microphone of a connected headset or the integrated microphone if no headset is connected. When you press the button a second time, the microphone is deactivated. Refer to the separate chapter on “Menu items”.
- Please keep a distance of approx. 10 cm to the integrated microphone when speaking.

Note:

- The integrated microphone was specially developed for the talkback function in conjunction with the Unite TP or TH transmitter for talking. For best audio transmission we recommend using an external headset.
- When the talkback button **6** is pressed, the active function is also displayed by .

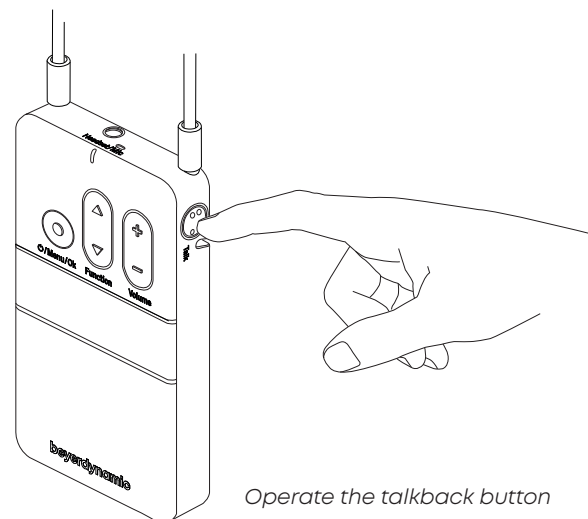

Operate the talkback button

10. Menu items

10.1 General

Once you have turned on the Unite TP bodypack transmitter or Unite TH handheld transmitter and the Unite RP bodypack receiver, press the O /Menu/Ok button **2** for approx. 2 seconds to access the menu. Press the button **2** again to access the respective menu or submenu. Use this button also to save or confirm the desired setting.

Use the multifunction button **4** to scroll through the menu and to carry out various settings within the respective menu.

Depending on the device, up to 4 main menus with submenus are available:

- Audio
- Talkback
- Bluetooth® (TP TH only)
- System

The dashes at the bottom of the display in the individual menus show how many submenus or setting options are available in the respective menu.

If no setting is made or changed or if the button is not pressed, the display returns to the main screen after a few seconds.

An active function is indicated by a highlighted display. **Example:** A transmitter is defined as "Master". As long as the function is not active, "Master" is displayed by a white "M" on a black background. When the "Master" function is active, the "M" is highlighted, i.e. the "M" turns black on a white background. Refer also to the illustration "Main screen" with an active "Master".

Main menu items

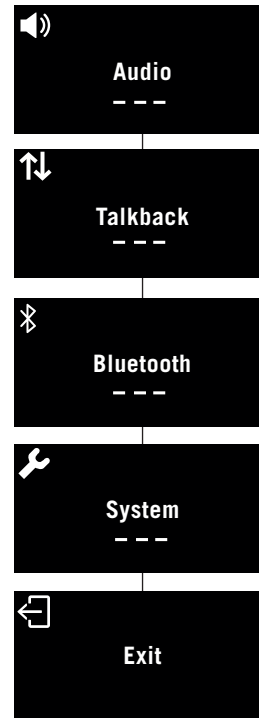







Main screen



















10.2 “Audio” main menu

In the “Audio” main menu, the menus listed in the following table (menu path / level 2) with more submenus (menu path / level 3) are available for various audio settings.





- Press the /Menu/Ok button  on the already **switched on** transmitter/receiver for approx. 2 seconds to access the menu.
- Briefly press the button  to access the “Audio” main menu.
- Press the multifunction button  to select the “Volume”, “Microphone”, “Quality”, “Mute Button”, “Line In Aux” or “Input Effects” submenu.
- Briefly press the button  to access the respective submenu.
- Press the multifunction button  to make settings in the respective submenu.
- Briefly press the button  to confirm the setting.

10.2.1 Basic audio settings

Device	Menu path Level 2	Menu path Level 3	Adjustable parameters	Description
  	Volume	HP Initial Level	25 steps (0 to 24)	HP stands for headphones. When the device is turned on, the overall volume is defined. When the device is restarted, the original volume is restored.
	Volume	Mini XLR Mic	13 steps (0 to 12)	This menu is used to adjust the sensitivity (mic gain) of the mini XLR microphone jack.
 	Volume	Headset Mic	13 steps (0 to 12)	This menu is used to adjust the sensitivity (mic gain) of the headset microphone connected to the 3.5mm mini jack socket.
 	Volume	Internal Mic	13 steps (0 to 12)	This menu is used to adjust the sensitivity (mic gain) of the internal microphone, if present.
	Volume	Line In	13 steps (0 to 12)	This menu is used to adjust the input sensitivity of the mini jack input line (3.5mm).
 	Volume	Sidetone	13 steps (0 to 12)	It is also possible to transmit your own microphone signal on the headphone connector if you wish to hear your own voice. Volume for this is adjusted in this menu.
 	Microphone		Internal Mini XLR Headset	The source of the microphone signal is selected in this menu.
	Quality		HD SD	HD (high quality, 22.3 ms latency) 50–14,000 Hz frequency range SD (low quality, 18.3 ms latency) 200–7,000 Hz frequency range
	Mute Button		Push Toggle	The mute button can be used in two different ways. “Push” means the device’s own microphone signal is muted for as long as the button is held down. “Toggle” means the microphone is muted when pressed once and reactivated when pressed a second time.
	Line In Aux		All Master Master & Sub-Masters	This menu is used to establish which devices in the group can hear the signal available on the analogue line-in input.

10.2.2 Set input effects

The Unite system has a built-in DSP (Digital Signal Processor) for continuous processing of audio signals during operation. In the “Audio” main menu, the “Input Effects” submenu contains various filter settings for processing audio signals.

Device	Menu path Level 2	Menu path Level 3	Menu path Level 4	Adjustable parameters	Description
 	Input Effects	ALC		Off Low High	ALC stands for “Automatic Level Control”. With this option, the device automatically adjusts microphone amplification with the aim of ensuring a signal volume that remains as consistent as possible. This significantly enhances speech intelligibility. Please note: ALC is not available for the internal microphone. When ALC is active, the static settings for sensitivity of audio inputs in the “Audio/Volume” menu are disregarded and have no further influence upon signal processing.
 	Input Effects	Low-Cut Filter		Off (50 Hz) 80 Hz 120 Hz 180 Hz 250 Hz	A low cut is an equaliser setting or filter effect setting that cuts out all frequencies below a preset frequency.
 	Input Effects	Equalizer		Off Female Male	The equaliser (EQ) is a filter used to design the sound of the input audio signal. The settings options are “female” for female speakers and “male” for male speakers. The preset “High Noise” is for use in extremely noisy environments to ensure speech intelligibility despite loud background noise. This is particularly useful when the filters for background noise reduction (Noise Gate and Noise Canceler) no longer function on account of extreme background noise.
 	Input Effects	Noise Gate	State	Off On	The Noise Gate is a filter effect in the category of dynamic processors and suppresses low signal transmission.
 	Input Effects	Noise Gate	Threshold	13 steps (-48 dB to -12 dB)	In the Threshold menu you can set the threshold value above which the background noise is muted. The lower the background noise, the lower the threshold value should be set.
 	Input Effects	Noise Canceller		Off Low Mid High	Noise cancellation (ANC) is a smart, adaptive way of eliminating noise. The Noise Canceler in Unite works extremely well with continuous background interference. This filter is capable of “learning” to identify and eliminate noises, ensuring that only the voice is audible via the microphone input where possible. Background noises in the settings “low” are eliminated using lower volume, and for “mid” to “high” using high volume.
 	Input Effects	Compressor		Off Low High Less Pop Noise	A compressor in sound engineering belongs to the group of dynamic processors. It serves to restrict the signal’s dynamic scope. The settings options “Low” and “High” represent the degree of compression of the input signal. Regardless of the microphone used, it may be that plosive sounds (e.g. P, B, T, D, K) may cause distortion for the listener. To reduce this “pop” effect there is also a “compression” setting for additional reduction of unwanted sounds.
	Input Effects	Ducker		Off Low Mid High	Ducking is a common expression in sound engineering for giving specific automatic prominence to an audio signal. This is achieved by decreasing other signals rather than increasing the signal to be given prominence. This effect can be used when an external audio signal is transmitted as an analogue signal or via USB. Depending upon the level (“Low” or “High”) of the setting, this external signal is then reduced as soon as the microphone is in use.

10.3 “Talkback” main menu

In the “Talkback” main menu, the menus listed in the following table (menu path / level 2) with further submenus (menu path / level 3) are available for various system settings.

- Press the $\text{O}/\text{Menu}/\text{Ok}$ button **2** on the already **switched on** transmitter/receiver for approx. 2 seconds to access the menu.
- Press the multifunction button **4** to select the “Talkback” main menu.
- Briefly press the button **2** to access the “Talkback” main menu.
- Press the multifunction button **4** to select the “Talk Button” or “Audio Routing”.
- Briefly press the button **2** to access the respective submenu.
- Press the multifunction button **4** to make settings in the respective submenu.
- Briefly press the button **2** to confirm the setting.

Device	Menu path Level 2	Menu path Level 3	Adjustable parameters	Description
RP-T	Talk Button		Push Toggle	With the “ Toggle ” setting selected, press the Talkback button once to switch on the internal or connected headset microphone. By pressing the button twice, the microphone will be deactivated. In the “ Push ” setting, the relevant microphone is activated only for as long as the Talkback button is pressed.
TP	Audio Routing	RP Talkback	All Master Master & Sub-Masters	This menu is used to set the routing of talkback signals. Master: only the Master device can hear the talkback signals. Master+Sub-Master: only Master and Sub-Master can hear the talkback signals. All: All devices in a specific group are able to listen in on talkback signals.
TP	Audio Routing	Sub-Masters	All Master Master & Sub-Masters	This menu is used to set the routing of audio signals from devices configured as Sub-Master. Master: only the Master device can hear audio signals from the Sub-Master. Master+Sub-Master: only the Master and all other Sub-Masters can hear audio signals from all Sub-Master devices in a group. All: All devices in a specific group are able to listen in on the signals of Sub-Master devices.

10.4 “Bluetooth” main menu

In the “Bluetooth” main menu, the menus listed in the following table (menu path / level 2) with further submenus (menu path / level 3) are available for various system settings.





























- Press the $\text{O}/\text{Menu}/\text{Ok}$ button **2** on the already **switched on** transmitter/receiver for approx. 2 seconds to access the menu.
- Press the multifunction button **4** to select the “Bluetooth” main menu.
- Briefly press the button **2** to access the “Bluetooth” main menu.
- Press the multifunction button **4** to select the “State”, “Connect” or “Pair” submenu.
- Briefly press the button **2** to access the respective submenu.
- Press the multifunction button **4** to make settings in the respective submenu.
- Briefly press the button **2** to confirm the setting.

Device	Menu path Level 2	Menu path Level 3	Adjustable parameters	Description
TP	State		Off Headset Phone / PC	The Bluetooth® interface can also be used both for playing in external audio material and playing back audio signals. This menu is used to set Bluetooth® mode. When set to “Phone/PC”, the device serves as an external soundcard and can be connected to a smartphone, PC or Mac computer.
TP	Connect			In this menu, devices are listed with which you have already successfully performed a Bluetooth® connection.
TP	Pair			To connect Unite via Bluetooth® to another device, it must first be paired with the connecting device. Go into this menu to get a list of all active, potential devices in the immediate vicinity. Select the device you wish to pair with and follow the instructions on both devices – Unite and the external device.

10.5 “System” main menu

In the “System” main menu, the menus listed in the following table (menu path / level 2) with further submenus (menu path / level 3) are available for various system settings.

- Press the /Menu/Ok button **2** on the already **switched on** transmitter/receiver for approx. 2 seconds to access the menu.
- Press the multifunction button **4** to select the “System” main menu.
- Briefly press the button **2** to access the “System” main menu.
- Press the multifunction button **4** to select the “Channel Name”, “Group ID”, “Display”, “Radio Power”, “Device Mode”, “Power Lockable”, “Reset” or “Information” submenu.
- Briefly press the button **2** to access the respective submenu.
- Press the multifunction button **4** to make settings in the respective submenu.
- Briefly press the button **2** to confirm the setting.

Device	Menu path Level 2	Menu path Level 3	Adjustable parameters	Description
  	Channel Name		5 characters (big and small letters, special characters and numbers)	In this menu, the channel name displayed on the bodypack receivers can be set. The channel to which the receiver is to connect can also be entered on the receivers. In this case it is not necessary to perform a channel search.
  	Group ID		1 to 256	In this menu you can set the group ID for devices (transmitter and receiver) that are used within a defined group.
  	Display	Brightness	10 steps (10 to 100%)	In this menu you can adjust the general brightness of the display.
  	Display	Dimming Level	11 steps (Off to 100%)	In this menu you can set the value to which the brightness of the display is reduced after the dimming time has been reached. With the setting “Off” is selected, the display is completely switched off.
  	Display	Dimming Time	17 steps (Off to 4 min)	In this menu you can select the time from which the selected dimming level value is applied to the brightness of the display.
	Radio Power		Std Mid Low	In this menu the transmission power of the transmitter is defined from standard to low. You can use this setting to reduce the range to bodypack receivers, if you want to operate several transmitters in adjacent rooms simultaneously.
	Device Mode		Master / Sub-Master	This menu is used to switch the device mode of the TP devices. In “Sub-Master” mode, the device behaves like an RP-T, with the difference that a fixed audio channel is reserved for this Sub-Master and it can continue to offer connection options for external devices. For more on this, see the chapter: “Sub-Master device mode” Important: If you change and confirm this setting, the device switches off. Please switch it on again. Please wait until the device has reconfigured and the main screen is displayed.
  	Power Lockable		Off On	When this option is activated (“On”), it is not possible to switch the device off manually by holding down the On-off and Menu button.
  	Reset		Factory	The “Reset” menu resets the device to the factory settings. All pairing information is deleted. Please refer also to chapter “Create/define a new pairing”.
  	Information	Battery		Battery information: Remaining capacity (Charge) Charging state (Charging) Current power consumption (Average power) Battery temperature (Temperature) Display of time to full or empty (time to full or time to empty)
  	Information	Device		Current firmware version (Firmware version) Build number of the firmware (Firmware build) Hardware address of the DECT interface (DECT ID) Production date (Production date) Serial number (Serial number) Built-in hardware version (Hardware version) Firmware version for Bluetooth (Bluetooth® version)

11. Special features

11.1 Device mode / Sub-Master configuration

- With Unite, the devices are basically divided into the categories “Master” (transmitter) and “Slave” (receiver).
- Devices of the type “RP” (RP; RP-T) are automatically configured “Slave” and devices of the type “TP” have the factory preset “Master”.
- Devices of the type “TP” can be configured as Sub-Master to a virtual device mode (Menu: System/Device Mode). In this mode a “TP” functions like an “RP-T”. As with an “RP” and “RP-T”, a channel search must be carried out in order to connect the Sub-Master to a Master (see chapter “Channel search”) and the basic conditions for establishing a connection must be met (see chapter “Create/define a new pairing”). The device differs from a standard “RP-T” in that a permanent Talkback channel is reserved for the Sub-Master. This audio channel is permanently open, but can be muted using the “Mute” button on the Sub-Master. In addition, there remains the option of connecting external audio sources to the “TP” configured as Sub-Master. The external audio signals are then routed (broadcast) via the “Master” to the group.

Caution:

Changing configuration between “Master” and “Slave” takes a few minutes. This involves restarting the device. In order to make use of this function, all devices must be within range.

11.2 Talkback function (RP-T)

- The orange Talkback button on the RP-T is used to activate the internal or externally connected microphone on the RP-T device.
- The group’s Master device is used to establish which devices in the group can hear the audio signals from individual devices with activated talkback channel (Menu: Talkback/Audio Routing*/RP Talkback).
- Transmission of all audio signals within a group is always via the group’s central Master (TP) (Broadcast; see fig.: Guided tours with talkback).
- A talkback signal from an RP-T device is thus first sent to the Master (TP) device for transmission to the group. This principle is valid for all signals within a group, including all external signals (fig.: Sound transmission).

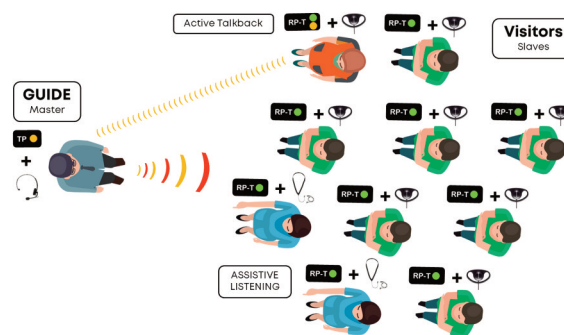

Guided tours with talkback

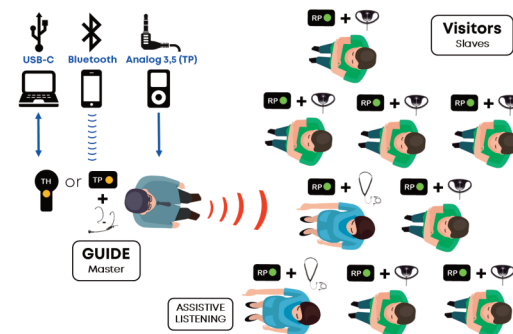

Sound transmission

*Function probably available from V1.1

11.3 NOM - Number of open microphones

- Unite can route a maximum of three simultaneously activated audio signals within a group (NOM=3). This means that, in addition to a group's Master device, two talkback channels can be activated simultaneously.
- Unite offers the option to set up whether there should be one or two talkback channels (Menu: Talkback / NOM Talkback*).
- When a Sub-Master is active in the group, the number of additional talkback channels that can be activated is reduced to one (fig.: Guided tours with two guides).

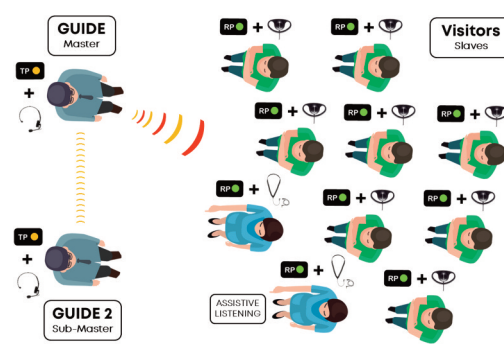

Guided tours with two guides

*Function probably available from V1.1

11.4 Channel search

The “Channel” multifunction button ④ of the receiver (Unite RP and RP-T) is also used for channel search.

- When you press ▲ or ▼ of the multifunction button, the device asks if a channel search should be carried out. Upon confirmation via the ⏻/Menu/Ok button ②, the device will search for compatible wireless transmissions.
- Both, transmitter and receiver, must have the same ID and key (see chapter “Create / define a new pairing”) to establish a connection between them.
- The scanning procedure is also a dynamic process as the automatic frequency management. This means that the devices scan continuously and do not stop this process independently.
- Once the receiver has found one or more channels, press the ▲ or ▼ of the multifunction button ④ to select a channel.
- Press the button ② to confirm the selected channel. The receiver then connects to the selected channel. This usually takes place within one second, however, due to various influencing factors it can also take several seconds.

Example: A high number of wireless connections in the immediate vicinity and/or too great a distance between transmitter and receiver.

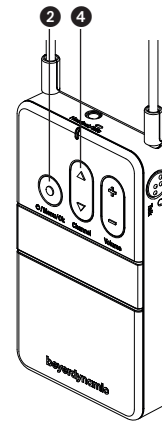

Channel search with a receiver

11.5 External interfaces (analogue line-in; USB interface; Bluetooth®)

Devices of the type “TP” also offer interfaces with which audio signals can be received and/or played.

The analogue line-in is a 3.5mm 3-pole mini jack connector. Please note that a stereo signal in Unite is converted to a mono signal.

The “TP” device has a USB interface (USB 2.0) with a type C connection port. This interface can play audio in and out simultaneously. When connected to a PC or Mac computer, the device serves as an external soundcard. Moreover, the device can be supplied with power and recharged via the USB port.

The Bluetooth® interface can also be used both for playing in external audio material and playing back audio signals. This depends upon configuration within the Bluetooth® menu (phone/PC; headset). You can also use a Bluetooth® headset. Please be aware that use of Bluetooth® in general will result in additional latency.

12. Special functions

12.1 Button lock

The button lock is a hidden function and is activated and deactivated as follows:
 Press and hold simultaneously one of the volume buttons and one of the “Function” buttons (RP; RP-T: “Channel” buttons) crosswise and for approx. 3 seconds. After activation/deactivation, the display “Button locked”/“Button unlocked” will appear.
 As soon as the button lock is activated, you cannot use the \odot /Menu/Ok button to enter the menu or to switch off the transmitter/receiver.
 This prevents switching off the device accidentally and unintentional changes to the menu settings.
 The volume can still be increased or decreased by pressing the volume button.

Example:

Press and hold the upper volume button and the lower function button (RP; RP-T: channel button) or the lower volume button and upper function button (RP; RP-T: channel button) for more than 3 seconds.

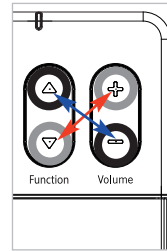

Press buttons crosswise

12.2 Automatic headset recognition



Unite has automatic headset recognition at the 3.5 mm jack socket. As soon as a device is connected to this jack socket you will be asked whether a headset or headphones without microphone have been connected. The “Audio / Audio Source” menu is configured accordingly.

12.3 Automatic power off

All RP, RP-T and TP devices configured by you as Sub-Master switch off automatically if no connection is made to a master device for at least 15 minutes (Display: “No RF”).

13. Accessories

Model	Description	Order #
DT 1	Single-ear headphone with 0.9m cable and stereo mini jack connector	724.521
DT 2	Headphone with 0.8m cable and stereo mini jack connector	484.679
IL 200	Induction loop with 0.7m cable and stereo mini jack connector	725.161
TG-H 56	Condenser neckworn microphone with mini XLR connector	705.888
	Neck strap	668.966
	Belt clip	662.658
Unite CC Bag	Storage bag for optional accessories (e.g. headphones)	713.066

14. Overview Unite components

Model	Description	Order #
Unite TP	Digital bodypack transmitter, incl. belt clip	*EU: 710.709 **NA: 739.294 ***JP: 739.340
Unite RP	Digital bodypack receiver, incl. belt clip	EU: 710.679 NA: 739.251 JP: 739.316
Unite RP-T	Digital bodypack receiver with talkback function, incl. belt clip	EU: 710.687 NA: 739.278 JP: 739.324
Unite CC-24P	Charging and transport case with a maximum of 24 charging compartments for Unite bodypack transmitters and receivers, network connection, integrated power supply	713.074
Unite CC-36P	same as above, but with a maximum of 36 charging compartments for Unite bodypack transmitters and receivers	728.306

15. Technical specifications

Unite RP, RP-T

DECT RF frequency range	1880 - 1930 MHz, depending on the country
DECT transmission power	up to 250 mW (peak), depending on the country
DECT operating range	up to 300 m outside (line of sight); the actual operating range depends upon the RF output settings, the surroundings, the signal absorption, signal reflection and signal interference
Audio bandwidth	
Low quality (SD)	200 Hz - 7 kHz (-3 dB)
High quality (HD)	100 Hz - 14 kHz (-3 dB)
Operating mode	Broadcast and/or full-duplex on all routes
Encryption	AES-256 bit encryption
Headphone/headset/induction loop connector	4-pin mini jack, 3.5 mm, CTIA Standard
Integrated microphone	yes
Display	monochrome white OLED display with high contrast
Max. number of open microphones	3 (individual level control for each microphone)
Battery	lithium-ion battery pack, replaceable by service staff only
Battery monitoring	Battery status of remaining capacity via OLED display
Operating time of battery pack	> 15 hrs., typ.
Side-tone and microphone gain	individually adjustable
USB Type C connector	USB 2.0/3.0 standard, compatible to 5 V power supplies only, power consumption max. 500 mA
Strap anchor points	available, neck strap removable
Dimensions (W x H x D)	58 x 102 x 15.5 mm
Weight (incl. battery)	105 g
Temperature range	
Charging	0 to +35 °C
Operation	-10 to +40 °C
Storage	-20 to +50 °C
Relative humidity	0 to 90%

Unite TP

DECT RF frequency range	1880 - 1930 MHz, depending on the country
DECT transmission power	up to 250 mW (peak), depending on the country
DECT operating range	up to 300 m outside (line of sight); the actual operating range depends upon the RF output settings, the surroundings, the signal absorption, signal reflection and signal interference
Audio bandwidth	
Low quality (SD)	200 Hz - 7 kHz (-3 dB)
High quality (HD)	100 Hz - 14 kHz (-3 dB)
Operating mode	Broadcast and/or full-duplex on all routes
Encryption	AES-256 bit encryption
Headphone/headset/induction loop connector	4-pin mini jack, 3.5 mm, CTIA Standard
Microphone connector	4-pin mini XLR jack, male (4.5 V bias voltage, beyerdynamic TG pin assignment)

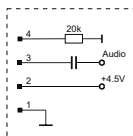

Integrated microphone	yes
Line-in	mini jack, 3.5 mm, max. -6 dBV / 0.5 V RMS
Display	monochrome white OLED display with high contrast
Max. number of open microphones	3 (individual level control for each microphone)
Battery	lithium-ion battery pack, replaceable by service staff only
Battery monitoring	Battery status of remaining capacity via OLED display
Operating time of battery pack	> 15 hrs., typ.
Side-tone and microphone gain	individually adjustable
Bluetooth®	V4.2 (HFP - Hands-Free-Profile, A2DP - Audiostreaming)
USB Type C connector	USB 2.0/3.0 standard, compatible to 5 V power supplies only, power consumption max. 500 mA
Strap anchor points	available, neck strap removable
Dimensions (W x H x D)	58 x 102 x 15.5 mm
Weight (incl. battery)	105 g

Temperature range	
Charging.....	0 to +35 °C
Operation.....	-10 to +40 °C
Storage.....	-20 to +50 °C
Relative humidity.....	0 to 90%

Unite CC

AC input.....	100 - 240 V AC, 50-60 Hz
Fuse.....	2 x 3.15 A (time-lag)
Nominal current.....	2.2 A @115 V AC, 1.1 A @230 V
Power consumption.....	150 W with 24 charging compartments 225 W with 36 charging compartments
Max. charging time.....	4 hours
Connections.....	Ethernet USB type C
Temperature range	
Operation.....	0 to +28 °C
Storage.....	-20 to +50 °C
Relative humidity.....	0 to 90%
Dimensions incl. handle, base (L x W x H).....	530 x 445 x 178 mm [20.7" x 17.5" x 7.0"]
Weight	
Unite CC-24P.....	12.3 kg
Unite CC-36P.....	12.7 kg
Charging compartments	
Unite CC-24P.....	max. 24 for bodypack transmitters / bodypack receivers
Unite CC-36P.....	max. 36 for bodypack transmitters / bodypack receivers

www.beyerdynamic.com



beyerdynamic GmbH & Co. KG

Theresienstraße 8 · 74072 Heilbronn · Germany

For further distributors worldwide, please go to www.beyerdynamic.com
Non-contractual illustrations. Subject to change without notice.

Weitere Vertriebspartner weltweit finden Sie im Internet unter www.beyerdynamic.com
Abbildungen nicht vertragsbindend. Änderungen vorbehalten.

EN 3 / BA UNITE (03.19)