

AC 3

Active Antenna Combiner

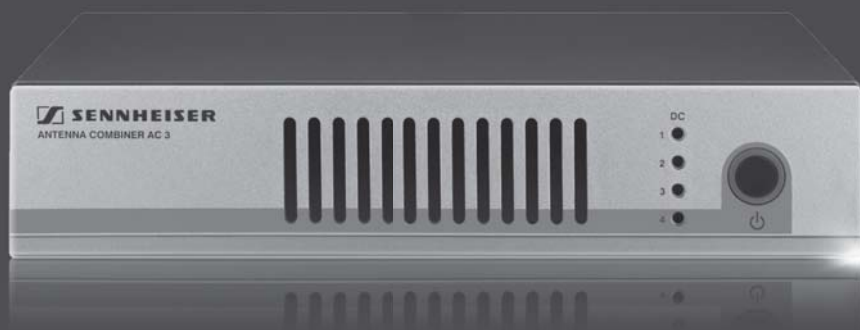

Instruction manual



Contents

- Important safety instructions 2
- The AC 3 active transmitter combiner 4
- Delivery includes 4
- Operating controls 5
- Block diagram 6
- Putting the AC 3 into operation 7
 - Preparing the AC 3 for use 7
- Using the AC 3 12
- Cleaning the AC 3 13
- If a problem occurs 14
- Accessories 15
- Specifications 16
- Manufacturer Declarations 17

Important safety instructions

- Read this instruction manual.
- Keep this instruction manual. Always include this instruction manual when passing the device on to third parties.
- Heed all warnings and follow all instructions in this instruction manual.
- Clean only with a slightly damp cloth.
- Refer all servicing to qualified service personnel. Servicing is required if the device has been damaged in any way, liquid has been spilled, objects have fallen inside, the device has been exposed to rain or moisture, does not operate properly or has been dropped.
- **WARNING:** To reduce the risk of fire or electric shock, do not use the device near water and do not expose it to rain or moisture. Do not place objects filled with liquids, such as vases or coffee cups, on the device.
- Only use the NT 3-1 table top power supply (see “Accessories” on page 15).
- Do not block any ventilation openings. Install the device in accordance with the instructions given in this manual.
- Do not install the device near any heat sources.
- Only use attachments/accessories specified by Sennheiser.

Replacement parts

When replacement parts are required, be sure the service technician uses replacement parts specified by Sennheiser or those having the same characteristics as the original part. Unauthorized substitutions may result in fire, electric shock, or other hazards.

Safety check

Upon completion of any service or repairs to this device, ask the service technician to perform safety checks to determine that the device is in a safe operating condition.

Intended use of the device

Intended use of the AC 3 includes:

- having read and understood this instruction manual especially the chapter “Important safety instructions” on page 2,
- using the device within the operating conditions and limitations described in this instruction manual.

“Improper use” means using the AC 3 other than as described in this instruction manual, or under operating conditions which differ from those described herein.

The AC 3 active transmitter combiner

With the AC 3 4-to-1 active transmitter combiner, the signals of up to four SR 300 IEM G3 type transmitters can be combined onto a single antenna.

The AC 3-US version is a special design approved for the U.S./Canada and is intended as a combiner for the SR 300 IEM G3 A1.

The integral active RF amplifiers ensure that the input signals are combined onto the common antenna output with no distribution attenuation.

The AC 3 incorporates DC distribution to enable simultaneous powering of up to four transmitters via its BNC sockets. A single NT 3-1 table top power supply (see "Accessories" on page 15) is required to power the AC 3 and the connected transmitters.

Using the GA 3 rack adapter (see "Accessories" on page 15), one AC 3 and one stationary SR 300 IEM G3 type transmitter can be mounted into a 19" rack.

Alternatively, you can stack the AC 3. For stacking the AC 3, mount the optional stacking elements (see "Accessories" on page 15).

The AC 3 is suitable for the following areas of application:

- Multi-channel monitoring systems for stage use
- Multi-channel systems suitable for any application where talk-back signals are to be transmitted (e.g. studio)

Delivery includes

- 1 AC 3 or AC 3-US active transmitter combiner
- 1 set of device feet
- 4 BNC cables
- 1 instruction manual

You additionally require the NT 3-1 table top power supply with a suitable mains connector (see "Accessories" on page 15).

Operating controls

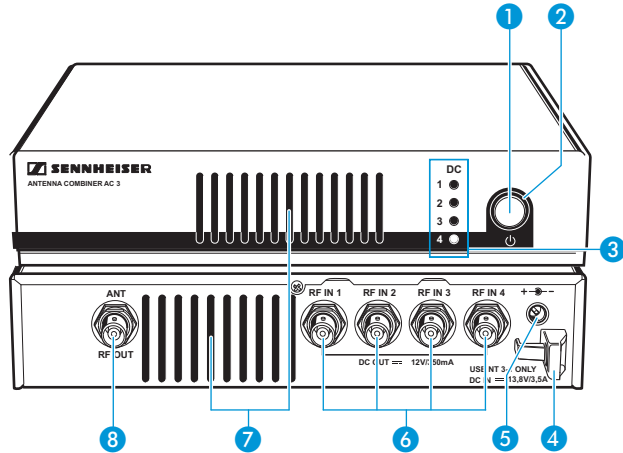

- 1 **STANDBY** button
- 2 Operation indicator
- 3 4 status LEDs
 - light up if the supply voltage for the transmitter is available at the BNC sockets **RF IN 1** to **RF IN 4**
 - go off if the BNC sockets **RF IN 1** to **RF IN 4** are short-circuited or if transmitters are connected that are not of the ew G3 series (e.g. transmitters of the ew G2 series)
- 4 Cable grip for cable of table top power supply
- 5 **DC IN** socket
for connection of NT 3-1 table top power supply
- 6 4 BNC sockets **RF IN 1** to **RF IN 4**
RF inputs for connection of the transmitters
Each of these RF inputs can power one transmitter.
- 7 Air vents
- 8 BNC socket **RF OUT**
for connecting the transmitting antenna

Block diagram

The below block diagram shows the connections for a 4-channel system with a single antenna.

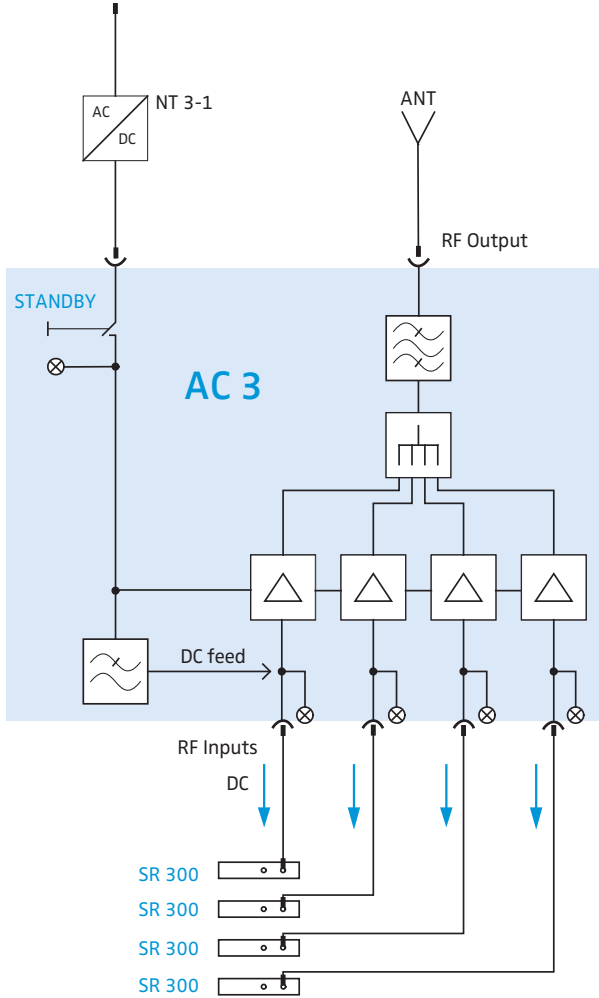

Putting the AC 3 into operation

Preparing the AC 3 for use

Setting up the AC 3 on a flat surface

- ▶ Place the AC 3 on a flat, horizontal surface.

Fastening the stacking elements



The stacking elements (see "Accessories" on page 15) are designed to help protect the operating elements from damage or deformation, e.g. if the AC 3 is dropped.

- ▶ Fasten the stacking elements even if you do not want to stack your AC 3.
- ▶ Do not fasten the stacking elements when mounting the AC 3 into a 19" rack (see page 9).

To fasten the stacking elements 9:

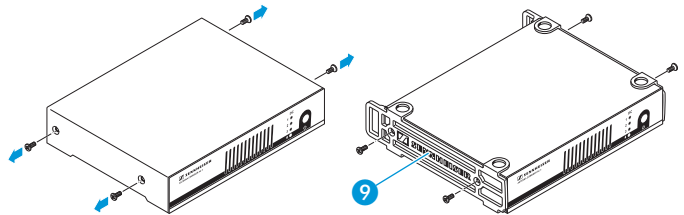

- ▶ Unscrew and remove the two recessed head screws (M4x8) on each side of the AC 3.
- ▶ Secure the stacking elements 9 to the sides of the AC 3 using the previously removed recessed head screws (see diagram).

**Stacking
several devices**

You can stack several AC 3 and the connected transmitters on top of each other.

CAUTION!



Danger of injury due to toppling stacks!

High stacks can easily topple over.

- ▶ Place the stack on an absolutely flat surface.
- ▶ Secure the stack against toppling over.

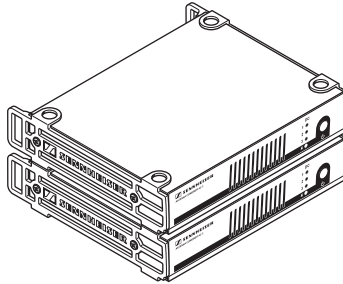

- ▶ Stack the devices so that the recesses of the stacking elements completely engage with each other.

**Fitting the
device feet**



If you want to stack the AC 3, only fit the device feet to the base of the lowermost device.

Do not fit the device feet when mounting the AC 3 into a 19" rack.

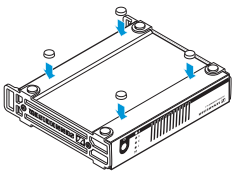

The device feet are fitted to the base of the AC 3 (see diagram).

- ▶ Clean the base of the AC 3 where you want to fix the device feet.
- ▶ Fix the device feet to the base of the AC 3 by peeling off the backing paper and fitting them as shown on the left.
- ▶ Place the AC 3 on a flat, horizontal surface.



Please note that the device feet can leave stains on delicate surfaces!

Mounting the AC 3 into a 19" rack

CAUTION!



Risks when rack mounting the device!

When installing the device in a closed or multi-rack assembly, please consider that, during operation, the ambient temperature, the mechanical loading and the electrical potentials will be different from those of devices which are not mounted into a rack.

- ▶ The ambient temperature within the rack must not exceed the temperature limit specified in the specifications.
- ▶ Ensure sufficient ventilation; if necessary, provide additional ventilation.
- ▶ Make sure that the mechanical loading of the rack is even.
- ▶ When connecting to the power supply, observe the information indicated on the NT 3-1 table top power supply. Avoid circuit overloading. If necessary, provide overcurrent protection.
- ▶ When rack mounting, please note that intrinsically harmless leakage currents of the individual power supplies may accumulate, thereby exceeding the allowable limit value. As a remedy, ground the rack via an additional ground connection.

Rack mounting one AC 3

- ▶ Secure the rack mount "ears" 10 (supplied with the optional GA 3 rack adapter) to the AC 3 in the same way as described for the stacking elements (see page 7).
- ▶ Secure the blanking plate 11 to one of the rack mount "ears" 10 using two recessed head screws (M 6x10) (see diagram on page 10).
- ▶ Insert the two blanking plugs 12 into the holes of the blanking plate (see diagram on page 10).

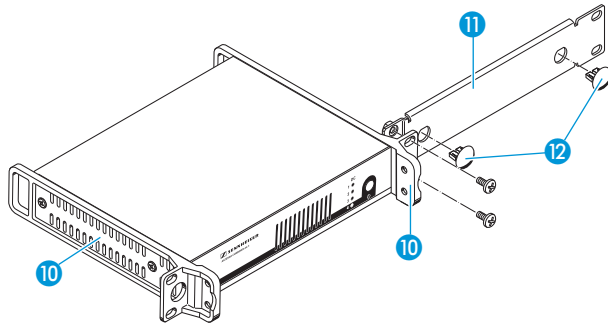

- ▶ Slide the AC 3 with the mounted blanking plate 11 into the 19" rack.
- ▶ Secure the rack mount "ear" 10 and the blanking plate 11 to the 19" rack.

**Rack mounting
two devices into
the same 19" slot**

To rack mount the AC 3 and an SR 300 IEM G3 type transmitter into the same 19" slot:

- ▶ Place the two devices side by side upside-down onto a flat surface:

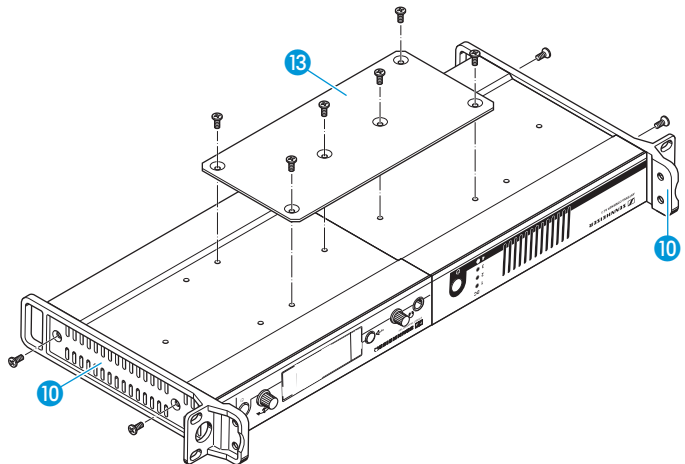

- ▶ Secure the jointing plate 13 to the devices using six recessed head screws (M 3x6).

- ▶ Secure the rack mount “ears” ⑩ (supplied with the optional GA 3 rack adapter) to the devices as described in the section “Fastening the stacking elements” on page 7.
- ▶ Slide the devices into the 19” rack.
- ▶ Secure the rack mount “ears” to the 19” rack.

Connecting devices to the AC 3

Connecting the antenna

We recommend connecting a remote antenna and, if necessary, using Sennheiser antenna accessories (see “Accessories” on page 15). For more information, refer to the ew G3 product page at www.sennheiser.com.

Connecting the transmitters

You can connect up to four stationary SR 300 IEM G3 type transmitters to the AC 3. The active transmitter combiner also incorporates DC distribution for powering the transmitters:

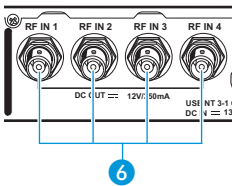

- ▶ Connect the transmitter’s antenna output to one of the BNC sockets **RF IN 1** to **RF IN 4** ⑥. Suitable BNC cables are included in the delivery. Transmitters of the ew G3 series do not require their individual power supply. They are now powered via the BNC sockets **RF IN 1** to **RF IN 4** ⑥.

Connecting the AC 3 to the mains

For powering the AC 3 and the connected transmitters, you require the NT 3-1 table top power supply (see “Accessories” on page 15).



Only use the NT 3-1 table top power supply with the red DC connector. It is designed for the AC 3 and ensures safe operation.

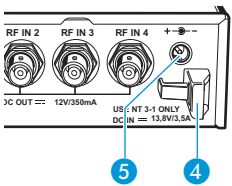

- ▶ Pass the cable of the NT 3-1 table top power supply through the cable grip ④.
- ▶ Insert the red DC connector of the NT 3-1 table top power supply into the **DC IN** socket ⑤.
- ▶ Plug the NT 3-1 table top power supply into a wall socket.

Using the AC 3

Switching the AC 3 on

CAUTION!



Risk of fire due to overheating of the AC 3!

The AC 3 equipped with a fan to assist dissipation of generated heat.

- ▶ Make sure that the air vents **7** of the AC 3 are not covered or blocked.



The fan of the AC 3 is temperature-controlled and operates only when required.

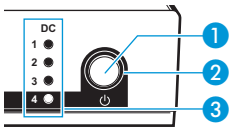

- ▶ Briefly press the **STANDBY** button **1**.
The operation indicator **2** lights up green. The LEDs 1 ... 4 **3** behave as follows:

LED 1 ... 4 3	Meaning
lights up	You have correctly connected an SR 300 IEM G3 type transmitter; the supply voltage for the transmitter is available at BNC socket RF IN 1 ... RF IN 4 .
does not light up	There is a short-circuit in the BNC socket RF IN 1 ... RF IN 4 : <ul style="list-style-type: none"> ▶ Read the chapter "If a problem occurs ..." on page 14.
	You have connected a transmitter that is not of the ew G3 series: <ul style="list-style-type: none"> ▶ Make sure that this transmitter has its own power supply.

The RF signals of the correctly connected transmitters are combined and transmitted via the connected transmitting antenna.

Setting the AC 3 to standby mode

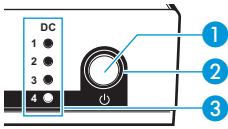

- ▶ Press the **STANDBY** button **1** for approx. 2 seconds. The operation indicator **2** and the 4 status LEDs **3** go off. The AC 3 switches to standby mode. Connected transmitters are switched off, provided that they are powered via the BNC sockets **RF IN 1** to **RF IN 4** **6**.

Disconnecting the AC 3 from the mains

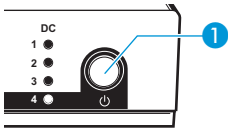

- The **STANDBY** button **1** does **not** disconnect the AC 3 from the mains. To disconnect the AC 3 from the mains:
- ▶ Unplug the NT 3-1 table top power supply from the wall socket. The AC 3 is switched off.

Cleaning the AC 3

CAUTION!

Liquids can damage the electronics of the device!

Liquids entering the housing of the device can cause a short-circuit and damage the electronics.

- ▶ Keep all liquids away from the device.
 - ▶ Do not use any solvents or cleansing agents.
-
- ▶ Before cleaning, disconnect the AC 3 from the mains (see page 13).
 - ▶ Only use a slightly damp cloth to clean the device.

If a problem occurs ...

Problem	Possible cause	Possible solution
Transmitters cannot be switched on	Transmitters are not powered	Check the connections of the NT 3-1 table top power supply and/or check the BNC sockets RF IN 1 to RF IN 4 6
	You have connected transmitters of the new G2 series	Make sure that these transmitters have their own power supply
Disturbed RF transmission	Antenna is not connected correctly	Check the antenna connection
	Connection cable is defective	Replace the connection cable
	Excessive RF signal attenuation due to too long antenna cable or incorrect type of antenna cable	Only use the recommended antenna cable (see "Accessories" on page 15) or use a shorter antenna cable or use a low-attenuation RF cable
LED 1 ... 4 3 does not light up	Short-circuit in the BNC socket RF IN 1 ... RF IN 4	Check the antenna connection Replace the connection cable
	You have connected transmitters of the new G2 series	Make sure that these transmitters have their own power supply

If a problem occurs that is not listed in the above table or if the problem cannot be solved with the proposed solutions, please contact your local Sennheiser partner for assistance.

Accessories

The following AC 3 accessories are available from your Sennheiser partner:

Cat. No. Accessory/spare part

568834	NT 3-1C EU	Table top power supply for powering the AC 3 and four transmitters, EU version
568835	NT 3-1C US	Table top power supply for powering the AC 3-US and four transmitters, 120 V version
568836	NT 3-1C UK	Table top power supply for powering the AC 3 and four transmitters, UK version

Mounting material

503167	GA 3	Rack adapter
532711		Stacking elements (1 pair)

Antennas

004645	A 1031-U	Broadband remote antenna
003658	A 2003-UHF	Broadband directional antenna

Antenna cables (coaxial cable)

002324	GZL 1019-A1	Type RG 58, BNC connectors, 1 m
002325	GZL 1019-A5	Type RG 58, BNC connectors, 5 m
002326	GZL 1019-A10	Type RG 58, BNC connectors, 10 m

Specifications

Frequency range	AC 3: 500 to 870 MHz AC 3-US: 470 to 698 MHz
Distribution attenuation	0 dB (± 1 dB)
RF input power	max. 30 mW per input
Impedance	50 Ω
Supply voltage	13.8 V DC (with NT 3-1 table top power supply)
Total current consumption	max. 3.4 A (with connected transmitters)
Supply voltage for transmitters at RF IN 1 to RF IN 4	11.4 V (protected from reverse feed), 350 mA
Relative humidity	5 to 95%
Operating temperature range	-10°C to +55°C
Storage temperature range	-20°C to +70°C
Dimensions of housing	approx. 212 x 168 x 43 mm
Weight	approx. 1470 g

In compliance with

Europe	 EMC EN 301489-1/-9 Radio EN 300422-1/-2 Safety EN 60065
--------	--

Approved by

Canada	Industry Canada RSS 210, IC: 2099A-AC3, limited to 698 MHz
USA	 CAN ICES-3(B)/NMB-3(B) 47 CFR Part 74 FCC-ID: DMOAC3, limited to 698 MHz

Australia



Manufacturer Declarations

Warranty

Sennheiser electronic GmbH & Co. KG gives a warranty of 24 months on this product.

For the current warranty conditions, please visit our web site at www.sennheiser.com or contact your Sennheiser partner.

In compliance with the following requirements

- WEEE Directive (2012/19/EU)



Please dispose of the AC 3 at the end of its operational lifetime by taking it to your local collection point or recycling center for such equipment.

CE Declaration of Conformity



- RoHS Directive (2011/65/EU)

- R&TTE Directive (1999/5/EG)

The declaration is available at www.sennheiser.com/download. Before putting the device into operation, please observe the respective country-specific regulations.

FCC & Industry Canada Information

This device complies with Part 15 of the FCC Rules. Operation is subject to the following two conditions:

- (1) This device may not cause harmful interference, and
- (2) this device must accept any interference received, including interference that may cause undesired operation.

This class B digital device complies with the Canadian ICES-003.

Changes or modifications made to this equipment not expressly approved by Sennheiser electronic Corp. may void the FCC authorization to operate this equipment. Before putting the device into operation, please observe the respective country-specific regulations!

Radiofrequency radiation exposure information:

This equipment complies with FCC and IC radiation exposure limits set forth for an uncontrolled environment. The AC 3 should be installed and operated with a minimum distance of 20 cm between the radiator and your body.



www.tourguide-systems.co.uk/sennheiser

Search: **@TourguideSYS**

Tel. +44 (0)1244 456 899



Sennheiser electronic GmbH & Co. KG

Am Labor 1, 30900 Wedemark, Germany
www.sennheiser.com
Publ. 10/16, 532863/A03